

Roll No.

--	--	--	--	--	--

Candidate should write his/her Roll No. here.

Total No. of Questions : 5

No. of Printed Pages : 8

M0912012
CIVIL ENGINEERING
First Paper

Time : 3 Hours]

[Total Marks : 300

Instructions to the candidates :

1. There are *five* questions in this question paper. *All* the *five* questions have to be answered.
2. The total number of marks is **300** and the time allotted is **3** hours. *All* questions carry equal marks, unless specifically stated.
3. The first question will be of short answer type consisting **20** questions, each **one** is to be answered in *one* or *two* lines.
4. Questions should be answered preferably in order in which they appear in the question paper. Answers to the various parts of the same question should be written together compulsorily and no answers of other questions should be inserted between them.
5. Assume suitable data wherever required.
6. All symbols have their usual meanings, unless mentioned otherwise.
7. Give neat sketches or diagrams wherever necessary.
8. Wherever word limit has been given it must be adhered to.
9. Use of I.S. Codes is permitted.

1. Write answer in *one* or *two* lines of the following questions : $20 \times 3 = 60$
- (A) Define "degrees of freedom".
 - (B) Define "static and kinematic indeterminacy".
 - (C) Explain "Mullar Breslau's" principle.
 - (D) State "Castigliano's Theorem".
 - (E) Differentiate between flexibility and stiffness approach of analysis.
 - (F) Why is the compaction essential in concrete ?
 - (G) Classify the rivet connections.
 - (H) What is the mode of failure of a R.C. beam ?
 - (I) Differentiate between expansion and contraction joints in concrete.
 - (J) Differentiate between Bond stress and Diagonal tension.

- (K) Write a note on "Contract Document".
- (L) List out the classification of Scheduling.
- (M) What do you mean by PERT ?
- (N) What is a critical path ? How is it identified ?
- (O) What is present worth of money ? Discuss its uses.
- (P) What do you mean by "Per Capita Sewage" ?
- (Q) Describe the laying of a sewer line in a trench.
- (R) Differentiate between "Manhole" and "Drop Manhole".
- (S) Explain "BOD" and "COD" in a sewage.
- (T) Describe the aim of the 'Sedimentation' in sewage treatment.

2. Determine the end moments of the members of the frame shown in Fig. (a).

E is constant and relative I values are indicated on the frame.

(Use Moment distribution method)

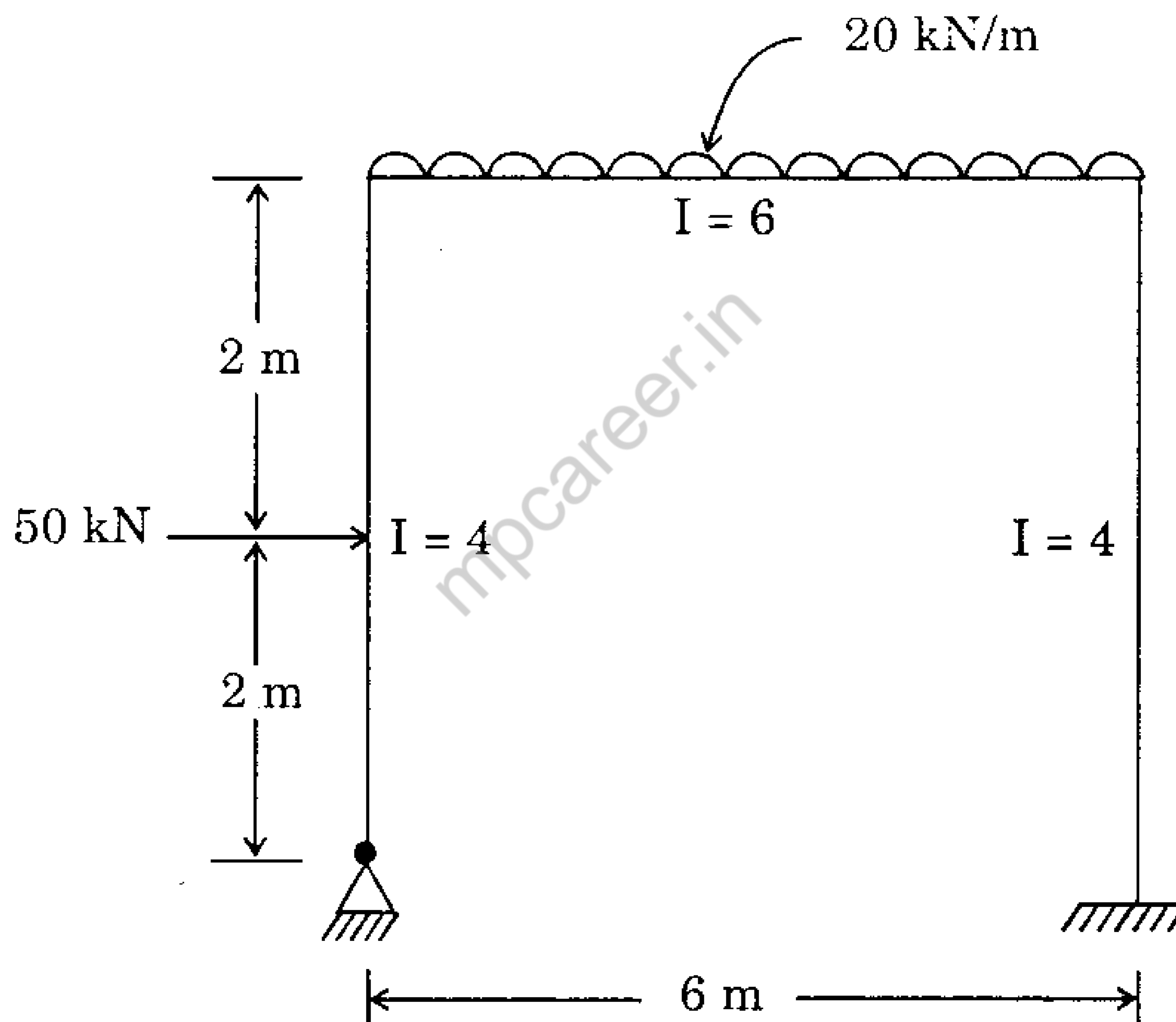

Fig. (a)

Then, draw the BMD and SFD for the frame.

Or

It is required to determine the approximate values of moment, shear and axial force in each member of frame shown in Fig. (b) using the Portal method. Draw BMD. 60

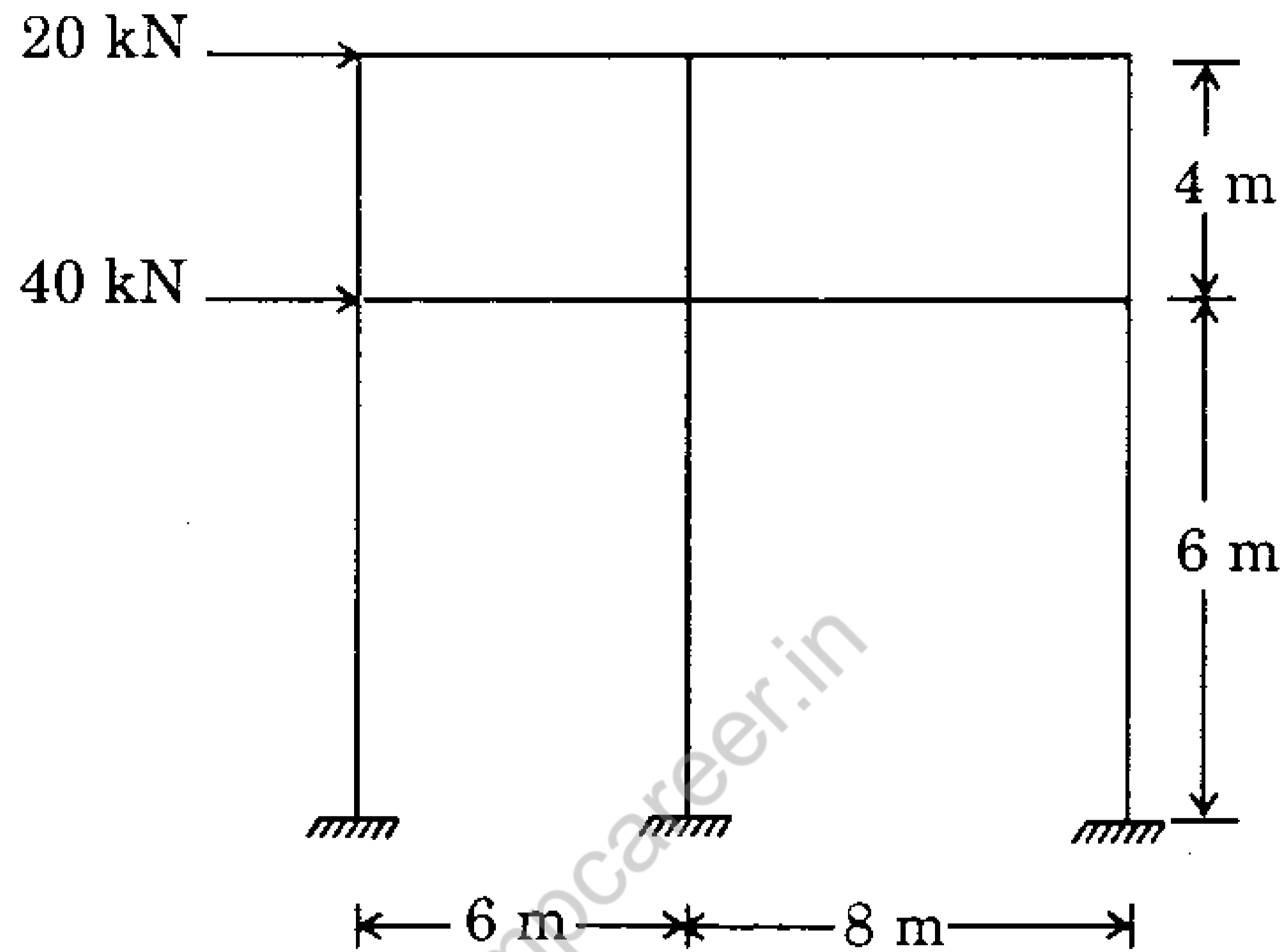

Fig. (b)

3. (a) A singly reinforced beam of concrete grade M25 has to resist an ultimate moment of 90 kN-m. Design the section using 0.9% steel of grade Fe415. Assume the width of the beam equal to 250 mm. Draw Reinforcements in a section. 30

- (b) Design a roof slab over a passage of size $14.77 \text{ m} \times 2.77 \text{ m}$ provided at the entrance of a public building. The slab is supported by 230 mm wide beams and carries superimposed load of 3.1 kN/m^2 . Use M20 mix and Fe415 grade of steel. Draw reinforcement details. 30

Or

- (a) Design an isolated rectangular sloped footing for the column of size $230 \text{ mm} \times 530 \text{ mm}$, reinforced with 6 bars of 20 mm diameter and carrying an axial load of 910 kN. The bearing capacity of the soil is 300 kN/m^2 . Use concrete grade M20 and steel grade Fe415. Effective cover for bottom steel is 60 mm. Take offset from the face of the column equal to 50 mm. 40
- (b) Define the losses in prestressed member in detail. How are they assessed ? 20

4. (a) A certain project takes 40 days along the critical path and has a variance of 9 days. Compute the expected completion time for the project with the following probabilities : 30

(i) 94.5%

(ii) 46%

(iii) 75%.

(b) If the period of incubation is 10 days at 20°C in the relative conductivity test on sewage, calculate the percentage of relative stability. 30

Or

(a) What do you mean by criticality and what are the different types of critical activities ? Explain briefly. 20

(b) What do you understand by self-purification property of a stream ? Explain the factors affecting this property. 20

- (c) What is meant by "Environmental pollution" Describe what happens when untreated sewage from a town is discharged into a nearby stream.

20

5. Write short notes on any *four* :

4×15=60

- (i) Types of sewers;
- (ii) Energy approach in structural analysis;
- (iii) Load balancing concept in prestress;
- (iv) Steps in design of tension members;
- (v) Cost control in construction projects;
- (vi) Types of tenders.

Roll No.

--	--	--	--	--	--

Candidate should write his/her Roll No. here.

Total No. of Questions : 5

No. of Printed Pages : 8

M0922012
CIVIL ENGINEERING
Second Paper

Time : 3 Hours]

[Total Marks : 300

Instructions to the candidates :

1. There are *five* questions in this question paper. *All the five* questions have to be answered. Question No. **2** to **5** have an internal choice.
2. The total number of marks is **300** and the time allotted is **3** hours. *All* questions carry equal marks, unless specifically stated.
3. The first question will be of short answer type consisting of **20** questions, each **one** is to be answered in *one* or *two* lines.
4. Questions should be answered preferably in order in which they appear in the question paper. Answers to the various parts of the same question should be written together compulsorily and no answers of other questions should be inserted between them.
5. Assume suitable data wherever required.
6. All symbols have their usual meanings, unless otherwise mentioned.
7. Give neat sketches or diagrams wherever necessary.
8. Where word limit has been given it must be adhered to.
9. Use of I.S. Codes is permitted.

1. Briefly answer the following (in 1-2 lines each) :

20×3=60

- (A) Give the use of Hydrograph.
- (B) What is crop rotation ?
- (C) Write Darcy's Law. Where is it applied ?
- (D) What are different types of Spillways ?
- (E) Why are galleries provided in a dam ?
- (F) Give the importance of canal falls.
- (G) Write objectives of river training works.
- (H) Give the functions of Base Course.
- (I) Give the significance of Wing Wall in a Bridge.
- (J) Write the use of C.B.R. Test on Subgrade soil.
- (K) What is track alignment ?

- (L) Define phase diagrams in a soil mass.
- (M) Write the factors affecting permeability of a soil mass.
- (N) What is the importance of effective stress in soil mechanics ?
- (O) Define and give importance of "Degree of Compaction".
- (P) How is Afflux calculated in designing a Bridge ?
- (Q) Enumerate methods of determining shear strength of soil.
- (R) Differentiate between a flexible and rigid pavement.
- (S) Enumerate different types of piles.
- (T) Why is soil exploration needed ?
2. (a) State assumptions taken in the development of Dupit's equation. Define and give importance of the equation. State the discharge estimation in a land-mass of length ' l ' between two water bodies at different levels with recharge.

- (b) A, 3 hour storm occurs over a 65 sq. km area. From the following data, estimate the rainfall, excess for the entire area and its hourly distribution.

30

Sub Area (sq. km)	ϕ index (cm/hour)	Hourly rain (cm)		
		1st	2nd	3rd
14.5	2.0	1.5	5.0	0.8
21.5	3.5	1.5	5.0	0.9
29.0	1.0	1.7	6.0	1.5

Or

- (a) Briefly describe and illustrate different forces which act on a gravity dam, with neat sketches show direction, location and magnitude.

25

(b) During a recuperation test, the water level in an open well, depressed 2.7 m and is recuperated by an amount of 1.5 m in 75 minutes.

(i) Determine the yield of a 3 m dia. well under a depression head of 3.5 m.

(ii) Also determine the diameter of a well having yield of 11 litre/sec. under a depression head of 2.5 m. 35

3. (a) Discuss the types and conditions for stability of substructures of a bridge. 25

(b) List out various factors, that influence the design of thickness of slab of a cement concrete road, and explain briefly how they influence the design with a suitable example. 35

Or

(a) Briefly explain, the method of Flexible Pavement Design by IRC-37, 2001 Code. 25

- (b) Give a typical dimensioned cross-section of a runway and a taxiway.

Also give details of the junction of Runway and Taxiway. 35

4. (a) With reference to consolidation of a soil mass, explain "Time factor". How is it related to average degree of consolidation.

Explain a curve fitting method to determine the coefficient of consolidation. 25

- (b) Two identical soil sample, tested in triaxial test apparatus, first sample failed at a deviator stress of 750 kPa when the cell pressure was 200 kPa. Second sample, under a cell pressure of 400 kPa failed at a deviator stress of 1350 kPa. Determine the value of shear parameters. If the same soil is tested in a direct shear test, with a normal stress of 550 kPa, find shear stress at failure. 35

Or

(a) Define Active earth pressure. List out the assumptions taken in Rankine's theory. Show the earth pressure distribution on a retaining wall, assuming the soil is dry with a sloping back fill. 25

(b) A 2 m × 2 m size square footing, at a depth of 1.8 m rests on a pure clay with an unconfined compression strength of 150 kN/m². Taking the soil purely cohesive, bulk density 16.7 kN/m³, find :

(i) Ultimate Bearing Capacity—taking the soil as pure cohesive.

$$\phi = 0^\circ, N_c = 5.7, N_q = 1 \text{ and } N_\gamma = 0.$$

(ii) Safe Bearing Capacity—taking factor of safety = 3. Discuss the effect of water table on this value of safe bearing capacity. 35

5. Write brief notes on the following (any *four*) :

4×15=60

- (a) Use of hydraulic jump in design of Hydraulic structures;
- (b) Modulus of subgrade reaction and its estimation;
- (c) Drainage and its importance in Highway Engineering;
- (d) Ground improvement through soil stabilization;
- (e) Flow net, its important characteristics and uses;
- (f) Stability of slopes.