

PART B
General Engineering
(ELECTRICAL)

1. (a) The resistance of copper winding of a motor at room temperature of 25°C is $3.0\ \Omega$. After an extended operation of the motor at full load, the winding resistance increases to $4.0\ \Omega$. Find the temperature rise. Given that the temperature coefficient of copper at 0°C is $0.00426\ \Omega/^{\circ}\text{C}/\Omega$. 15
- (b) A toaster rated at $2000\ \text{W}$, $240\ \text{V}$ is connected to a $230\ \text{V}$ supply. Will the toaster be damaged? Will its rating be affected? 15
- (c) Define the following terms : 20
- (i) Drift velocity
 - (ii) Current density
 - (iii) Power
 - (iv) Electromotive force
- (d) The domestic power load in a house comprises the following :
- (i) 10 lamps of $100\ \text{W}$ each
 - (ii) 5 fans of $80\ \text{W}$ each
 - (iii) 1 refrigerator of $0.5\ \text{hp}$
 - (iv) 1 heater of $1\ \text{kW}$
- Calculate the total current taken from the supply of $230\ \text{V}$. 10

2. (a) Using Kirchhoff's law, determine the current I_A and I_B in the network shown in Figure 1. 15

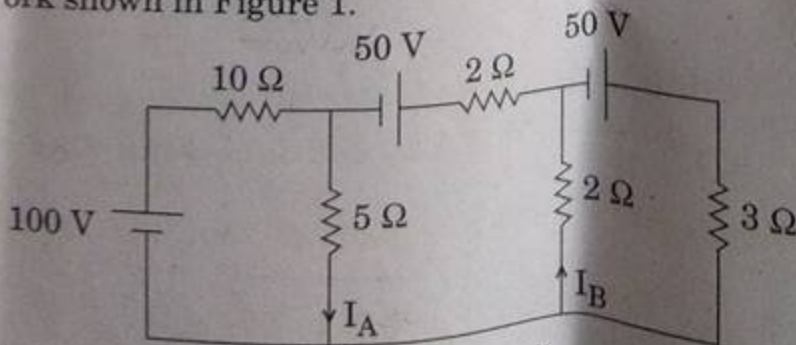

Figure 1

- (b) For the circuit shown in Figure 2, find I such that current in the $100\ \Omega$ resistor is zero. 15

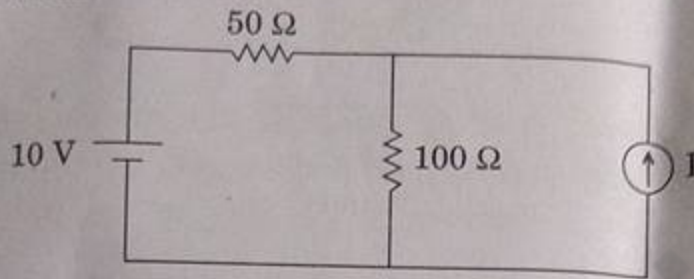

Figure 2

- (c) A series combination of two capacitances $C_1 = 5\ \mu\text{F}$ and $C_2 = 10\ \mu\text{F}$ is connected across a dc supply of 300 V. Determine the

- (i) charge
 - (ii) voltage
 - (iii) energy stored in each capacitor
- 15

- (d) Define the following terms :

- (i) Self-inductance
 - (ii) Flux
 - (iii) RMS value of alternating waves
- 15

3. (a) A circular coil of area $300\ \text{cm}^2$ and 25 turns rotates about its vertical diameter with an angular speed of $40\ \text{rad/sec}$ in a uniform horizontal magnetic field of magnitude $0.05\ \text{T}$. Find the maximum voltage induced in the coil. 10

- (b) Define the following terms :

- (i) Reluctance
 - (ii) Permeance
 - (iii) Magnetic Field Strength
- 15

- (c) ✓ A coil has 1000 turns enclosing a magnetic circuit of 20 cm^2 in cross-section. With 4 A current in the coil, the flux density is 1.5 Wb/m^2 , and with 8 A current, it is 1.9 Wb/m^2 . Find the mean value of inductance between these current limits and the induced emf if the current decreases from 8 A to 4 A in 0.05 sec. 15
- (d) ✓ A coil A of 1200 turns and another coil B of 800 turns lie next to each other so that 60 percent of the flux produced in one links with the other. It is found that a current of 5 A in coil A produces a flux of 0.25 mWb , while the same current in coil B produces a flux of 0.15 mWb . Determine the mutual inductance and coefficient of coupling between the coils. 20
4. (a) ✓ Determine the average and rms value of the resultant current in a wire carrying simultaneously a dc current of 10 A and sinusoidal current of peak value of 1.414 A. 10
- (b) ✓ The resistance of a coil is 3Ω and its time constant is 1.8 sec. At $t = 0$ sec, a 10 V source is connected to it. Determine the 15
- current at $t = 1$ sec
 - time at which the current attains half of its final value
 - initial rate of growth of current
- (c) ✓ Explain in brief the following : 20
- Energy meter
 - CRO
 - 2 wattmeter method
 - Multimeter
- (d) In a moving coil instrument, the coil has a length of 5 cm, a width of 4 cm and 100 turns. The magnetic flux density in the air gap is 0.2 Wb/m^2 . The hair spring provides a controlling torque of $0.5 \times 10^{-7} \text{ Nm/degree}$ deflection of the coil. What current will be required to give a deflection of 60° ? 15

5. (a) A shunt generator gives full load output of 30 kW at a terminal voltage of 200 V. The armature and shunt field resistances are 0.01 Ω and 100 Ω respectively. The iron and friction losses are 1000 W. Calculate the
- (i) emf generated
(ii) copper losses
(iii) efficiency

$$E_g = V + I_a R_a$$
$$= 200 + 17$$

- (b) Explain dynamic braking of 3-phase induction motor. 15
- (c) Explain in brief the following : 15
- (i) Fractional kilowatt motors
(ii) Auto transformers
(iii) S.C. test of 3-phase transformer

- (d) Explain parallel operation of two alternators. 15

6. (a) Explain in brief of the following : 30
- (i) Merz-price system of protection
(ii) Short-circuit current for symmetrical faults
(iii) Electric welding

- (b) How is the rating of a cable determined ? 10

- (c) What are the different configurations of BJT ? Explain each with suitable circuit diagram. 10

- (d) Explain electric installation of machines and relevant IE rules in brief. 10