

---

# RRB JE 2019 (CBT 2) (ME) Previous Year Paper (31 Aug 2019)

Total Time: 2 Hour

Total Marks: 150

---

## Instructions

Sl No.	Section Name	No. of Question	Maximum Marks	Negative Marks	Positive Marks
1	2nd Stage CBT	150	150	0.33	1

- 1.) A total of 120 minutes is allotted for the examination.
- 2.) The server will set your clock for you. In the top right corner of your screen, a countdown timer will display the remaining time for you to complete the exam. Once the timer reaches zero, the examination will end automatically. The paper need not be submitted when your timer reaches zero.
- 3.) There will, however, be sectional timing for this exam. You will have to complete each section within the specified time limit. Before moving on to the next section, you must complete the current one within the time limits.

---

## 2nd Stage CBT

1. Which two words appeared on the first postage stamp of independent India? (+1, -0.33)
- a. Jai Hind
  - b. Vande Mataram
  - c. Jai Kisan
  - d. Jai Bharat
- 
2. When Mach number is less than unity, the flow is called- (+1, -0.33)
- a. Hyper-sonic flow
  - b. Sonic flow
  - c. Super-sonic flow
  - d. Sub-sonic flow
- 
3. A cutting tool can never have its (+1, -0.33)
- a. Clearance angle – positive
  - b. Rake angle – positive
  - c. Clearance angle – negative
  - d. Rake angle – negative
-



---

4. The rate at which the entire organization generates money through sales for a product or service is **(+1, -0.33)**

- a. Operating expense
- b. Inventory
- c. Takt time
- d. Throughput

---

5. \_\_\_\_\_ is a group of fine holes on the surface of the weld caused by gas entrapment. **(+1, -0.33)**

- a. Gas pocket
- b. Blow holes
- c. Porosity
- d. Crack

---

6. In a vernier calliper, the main scale reads in millimetres with a least count of 0.1 mm. Ten divisions on the vernier correspond to nine divisions of the main scale. Determine the least count of the calliper. **(+1, -0.33)**

- a. 0.001 mm
  - b. 1 mm
  - c. 0.1 mm
  - d. 0.01 mm
-

---

7. What is meant by HVOF in metal coating? (+1, -0.33)

- a. High Velocity Oxidised Filler
- b. High Viscous Oxidised Fluid
- c. High Viscous Oxygen Fuel
- d. High Velocity Oxygen Fuel

---

8. Determine the elevation for  $30^\circ$  using 5.00" sine bar. (+1, -0.33)

- a. 2.5000"
- b. 2.8679"
- c. 3.8302"
- d. 1.7101"

---

9. \_\_\_\_\_ is used to move the carriage automatically during threading. (+1, -0.33)

- a. Bed
- b. Hand wheel
- c. Feed rod
- d. Lead screw

---

10. Control volume in a thermodynamic system refers to- (+1, -0.33)

- a. A specified mass in fluid flow

- 
- b. Mass that moves across the boundary
  - c. Transfer of energy across the boundary
  - d. Fixed region in space for thermodynamic study
- 

11. The temperature point at which the change starts on heating the steel is called (+1, -0.33)
- called
- a. Point of recalescence
  - b. Point of decalescence
  - c. Upper critical point
  - d. Lower critical point
- 

12. Which of the following operations does NOT use a Multiple-point cutting tool? (+1, -0.33)
- a. Broaching
  - b. Drilling
  - c. Turning
  - d. Milling
- 

13. If ' $\alpha$ ' is coefficient of thermal expansion, ' $\Delta T$ ' is magnitude of change in temperature and ' $E$ ' is modulus of elasticity, then the expression for thermal stress induced in a rod of length ' $l$ ' that is fixed between two rigid ends is given as- (+1, -0.33)
- a.  $\alpha E l \Delta T$

---

b.  $\alpha E \Delta T$

c.  $\alpha \Delta T / EI$

d.  $\alpha I \Delta T$

---

14. Grain size range between 90 and 220 is considered as- (+1, -0.33)

a. Very fine grain

b. Coarse grain

c. Normal grain

d. Fine grain

---

15. After New moon, the next fourteen days where the moon grows thicker and thicker and becomes visible as a full, near-perfect round moon is called as which phase of the moon? (+1, -0.33)

a. Waxing phase of the moon

b. Waning phase of the moon

c. Decreasing phase of the moon

d. Vanishing phase of the moon

---

16. Which of the following shutdown methods is often called Warm Boot? (+1, -0.33)

a. Restart

b. Sleep

---

c. Shut Down

d. Hibernate

---

17. The first instrument for routine monitoring of total ozone was developed by- (+1, -0.33)

a. William Sturgeon

b. Samuel Langley

c. Robert Moog

d. Gordon M. B. Dobson

---

18. Who has won the Sir Garfield Sobers Trophy for Cricketer of the Year 2017? (+1, -0.33)

a. Steve Smith

b. Virat Kohli

c. Ravindra Jadeja

d. Ravichandran Ashwin

---

19. Which of the following indicates the amount of superabrasive grit in a grinding wheel? (+1, -0.33)

a. Grade

b. Structure

c. Concentration

---

d. Grit

---

20. Silicon steel is widely used for- (+1, -0.33)

- a. Connecting rods
  - b. Transformers
  - c. Cutting tools
  - d. Motor crank shafts
- 

21. A hollow steel column has to carry an axial load of 2,00,000 kg and the ultimate stress for the steel column is  $4800 \text{ kg/cm}^2$  and allows a load factor of 4. What is the sectional area of the column? (+1, -0.33)

- a.  $196.66 \text{ cm}^2$
  - b.  $166.66 \text{ cm}^2$
  - c.  $180.66 \text{ cm}^2$
  - d.  $176.66 \text{ cm}^2$
- 

22. Paramparagat Krishi Vikas Yojana was launched in April, 2015 to support and promote- (+1, -0.33)

- a. Oil production
- b. Organic farming
- c. Wheat agriculture

---

d. Vegetable farming

---

23. The angle between the resultant reaction and normal to the plane on which the motion of body is impending is known as- (+1, -0.33)

- a. Angle of zenith
  - b. Angle of limiting friction
  - c. Angle of friction
  - d. Angle of repose
- 

24. Which of the following is an organic flux? (+1, -0.33)

- a. Tallow
  - b. Hydrochloric acid
  - c. Zinc chloride
  - d. Phosphoric acid
- 

25. Moment of inertia of a rectangular section having width (b) and depth (d) about an axis passing through its centre of gravity and parallel to the depth, is- (+1, -0.33)

- a.  $bd^3/36$
- b.  $db^3/36$
- c.  $bd^3/12$
- d.  $db^3/12$

---

---

26. The number '120' in the grinding wheel R D 120 N 100 M 4 specifies the \_\_ ( +1, -0.33)

- a. Concentration Number
  - b. Abrasive strength
  - c. Average grain size
  - d. Hardness of grinding wheel
- 

27. The ratio of oxygen to acetylene in the neutral flame is- ( +1, -0.33)

- a. 1:3
  - b. 2:1
  - c. 3:1
  - d. 1:1
- 

28. Where was the 27th Fusion Energy Conference (FEC) inaugurated on 22 October 2018? ( +1, -0.33)

- a. Haryana
  - b. Rajasthan
  - c. Gujarat
  - d. Punjab
  - e. Jharkhand
-



---

29. Participatory notes are associated with which of the following? (+1, -0.33)

- a. Foreign Institutional Investors
  - b. Port Folio Investors
  - c. Mutual Fund Investors
  - d. Cryptocurrency investors
- 

30. The horizontal feed in a lathe is controlled by- (+1, -0.33)

- a. Apron
  - b. Headstock
  - c. Cross-slide
  - d. Tailstock
- 

31. Which will form amphoteric oxide? (+1, -0.33)

- a. Zn
  - b. Na
  - c. Ca
  - d. Al
- 

32. Up milling is also called as (+1, -0.33)

- a. End milling

- 
- b. Face milling
  - c. Climb milling
  - d. Conventional milling
- 

33. Through which of the following states does the Chambal river flow? (+1, -0.33)

- a. Uttar Pradesh
  - b. Rajasthan
  - c. All of the options
  - d. Madhya Pradesh
- 

34. India's first National Centre for Marine Bio-diversity (NCMB) is located in- (+1, -0.33)

- a. Mumbai
  - b. Puducherry
  - c. Bhavnagar
  - d. Jamnagar
- 

35. For which surfaces, is a spirit level used for testing straightness ? (+1, -0.33)

- a. Horizontal surfaces
- b. Both Horizontal and vertical surfaces
- c. Inclined surfaces

---

d. Vertical surfaces

---

36. The failure of the material due to cyclic loads is known as- (+1, -0.33)

- a. Embrittlement
  - b. Fatigue
  - c. Impact failure
  - d. Creep
- 

37. When the dispersed phase is gas and dispersing medium is solid and the type of colloid is- (+1, -0.33)

- a. Aerosol
  - b. Gel
  - c. Emulsion
  - d. Foam
- 

38. The efficiency of a screw jack is maximum, when (+1, -0.33)

Where  $\alpha$  = Helix angle and  $\phi$  = Angle of friction.

- a.  $\alpha = 45^\circ + \frac{\phi}{2}$
- b.  $\alpha = 45^\circ - \frac{\phi}{2}$
- c.  $\alpha = 90^\circ + \phi$
- d.  $\alpha = 90^\circ - \phi$

---

---

39. The performance of cache memory is frequently measured in terms of a quantity called \_\_\_\_\_ . (+1, -0.33)

- a. Register
  - b. Associative Mapping
  - c. Hit ratio
  - d. Set-associative Mapping
- 

40. The height by which a tooth of a gear projects beyond the standard pitch circle or pitch line is technically known as- (+1, -0.33)

- a. Dedundum
  - b. Addendum
  - c. Pitch radius
  - d. Backlash
- 

41. Which of the following is equal to a pressure of 25 m head of water? (+1, -0.33)  
(Take  $g = 9.8 \text{ m/s}^2$ )

- a.  $25 \text{ kN/m}^2$
  - b.  $2500 \text{ kN/m}^2$
  - c.  $245 \text{ kN/m}^2$
  - d.  $2.5 \text{ kN/m}^2$
-

---

42. The electron distribution in a magnesium atom is- (+1, -0.33)

- a. 8, 2, 2
  - b. 8, 2, 3
  - c. 2, 8, 3
  - d. 2, 8, 2
- 

43. Which of the following distribution represents the time estimates in PERT ? (+1, -0.33)

- a. Poisson distribution
  - b. Normal distribution
  - c. Beta distribution
  - d. Weibull distribution
- 

44. The operation which is done to make periphery of grinding wheel concentric with its axis to recover its lost shape is known as- (+1, -0.33)

- a. Truing
  - b. Dressing
  - c. Glazing
  - d. Loading
- 

45. Chilled cast iron is produced\_ \_ \_ \_ \_ (+1, -0.33)

- a. All of the options

- 
- b. By adding magnesium to molten cast iron
  - c. From white cast iron by annealing process
  - d. By cooling of molten cast iron
- 

46. A hydraulic press is based on the principle of- (+1, -0.33)

- a. Boyle's law
  - b. Newton's law
  - c. Charles' law
  - d. Pascal's law
- 

47. When the pressure intensity at a point is more than the local atmospheric pressure, then the difference of these two pressures is called- (+1, -0.33)

- a. Positive gauge pressure
  - b. Barometric pressure
  - c. Absolute pressure
  - d. Negative gauge pressure
- 

48. Which of the following is an example of paramagnetic material? (+1, -0.33)

- a. Tantalum
- b. Gold
- c. Copper

---

d. Silver

---

49. The science that deals with the relationship of various organisms with their environment is known as- (+1, -0.33)

- a. Cytology
  - b. Geology
  - c. Anthropology
  - d. Ecology
- 

50. The sum of the clearance angle, rake angle and cutting wedge angle is always equal to\_ \_ \_ (+1, -0.33)

- a.  $360^\circ$
  - b.  $90^\circ$
  - c.  $180^\circ$
  - d.  $45^\circ$
- 

51. Nixan Gold Cup is associated with which sport? (+1, -0.33)

- a. Basketball
  - b. Badminton
  - c. Football
  - d. Volleyball
-

---

52. The first Commonwealth Games in 1930 was held in which country? (+1, -0.33)

- a. Australia
- b. England
- c. New Zealand
- d. Canada

---

53. Bimbisara was the ruler of- (+1, -0.33)

- a. Gandhara
- b. Magadha
- c. Taxila
- d. Mathura

---

54. Which carburising method has high production rate ? (+1, -0.33)

- a. Gas carburising
- b. Pack carburising
- c. Liquid carburising
- d. Solid powder carburising

---

55. In which of the following operation of lathe machine is the tool NOT feed in a straight path ? (+1, -0.33)

- a. Taper turning



---

b. Contour turning

c. Form turning

d. Facing

---

56. \_\_\_\_\_ is the death rate per thousand individuals (+1, -0.33)

a. Emigration rate

b. Natality rate

c. Mortality rate

d. Immigration rate

---

57. Cholera is caused by the bacteria called- (+1, -0.33)

a. Salmonella typhi

b. Clostridium botulinum

c. Treponema palladium

d. Vibrio cholerae

---

58. \_\_\_\_\_ is also called line layout. (+1, -0.33)

a. Process layout

b. Functional layout

c. Product layout

---

d. Fixed position layout

---

59. Which of the following processes is an example of a reversible process ? (+1, -0.33)

a. Heat transfer

b. Electrolysis

c. Combustion

d. Plastic deformation

---

60. The Stockholm Convention on Persistent Organic Pollutants (POPs) was signed in the year- (+1, -0.33)

a. 2000

b. 2001

c. 1998

d. 1999

---

61. Free of cost repair of software bug available at Internet is called .... (+1, -0.33)

a. Version

b. Ad-on

c. Tutorial

d. Patch

---

---

62. If  $W$  is weight of a body,  $\alpha$  is angle of an inclined plane and  $\phi$  is angle of friction, then the force required to drag the body when it is just impending to move the plane, is\_ \_ \_ \_ \_ (+1, -0.33)

- a.  $W \tan(\alpha + \phi)$
  - b.  $W \cos(\alpha + \phi)$
  - c.  $W \sin(\alpha + \phi)$
  - d.  $W \sec(\alpha + \phi)$
- 

63. What is the SI unit of Electric Potential Difference? (+1, -0.33)

- a. Watts
  - b. Volt
  - c. Ohms
  - d. Coulomb
- 

64. What is the chemical symbol of acetylene gas? (+1, -0.33)

- a.  $C_2H_2$
  - b.  $CH_3$
  - c.  $C_3H_2$
  - d.  $CH_2$
- 

65. Which of the following contains Citric acid? (+1, -0.33)

- 
- a. Tomato
  - b. Orange
  - c. Tamarind
  - d. Sour milk
- 

66. If the Reynolds number is less than 2000, the flow in pipe is - (+1, -0.33)

- a. Transitional from laminar to turbulent
  - b. Turbulent
  - c. Inviscid
  - d. Laminar
- 

67. Which of the following processes permits the transformation of austenite to martensite, throughout the crosssection of a component without cracking or distortion? (+1, -0.33)

- a. Austempering
  - b. Marquenching
  - c. Annealing
  - d. Tempering
- 

68. Which of the following processes uses non-consumable electrode? (+1, -0.33)

- a. MIG welding

---

b. Electroslag welding

c. TIG welding

d. Laser welding

---

69. Which of the following is NOT a type of virus? (+1, -0.33)

a. Polymorphic

b. McAfee

c. Multipartite

d. Boot sector

---

70. In Rockwell hardness testing method, the hardness of a material is measured by- (+1, -0.33)

a. Material failure

b. Surface roughness

c. Elongation of material

d. Depth of indentation

---

71. Gun metal contains 2 percent of- (+1, -0.33)

a. Copper

b. Tin

c. Nickel

---

d. Zinc

---

72. Heat is absorbed by a refrigerant during a refrigeration cycle in a- (+1, -0.33)

- a. Condenser
  - b. Throttle valve
  - c. Evaporator
  - d. Compressor
- 

73. What is the full form of CMM? (+1, -0.33)

- a. Current Measuring Machine
  - b. Coordinate Monitoring Machine
  - c. Coordinate Measuring Machine
  - d. Cantilever Measuring Machine
- 

74. Soft solder consists of- (+1, -0.33)

- a. Copper and tin
  - b. Lead and zinc
  - c. Lead and tin
  - d. Lead and aluminium
- 

75. The ratio of actual discharge of a jet of water to its theoretical discharge is (+1, -0.33)

---

known as-

- a. Coefficient of velocity
  - b. Coefficient of discharge
  - c. Coefficient of viscosity
  - d. Coefficient of contraction
- 

76. The internal energy of a perfect gas depends on (+1, -0.33)

- a. Temperature, entropy and specific heats
  - b. Temperature only
  - c. Temperature, pressure and specific heats
  - d. Temperature, enthalpy and specific heats
- 

77. Which of the following is the India's first Arctic Research station? (+1, -0.33)

- a. Himadri
  - b. Dakshin Gangotri
  - c. Maitri
  - d. Bharati
- 

78. Action and reaction act on (+1, -0.33)

- a. Same body and in same direction

- 
- b. Same body but in opposite direction
  - c. Different bodies but in same direction
  - d. Different bodies but in opposite direction
- 

79. Who among the following won the Orange Cap in the 2019 VIVO IPL? (+1, -0.33)

- a. KL Rahul
  - b. Shikhar Dhawan
  - c. David Warner
  - d. Chris Gayle
- 

80. In which of the following cities did the Jallianwala Bagh massacre take place? (+1, -0.33)

- a. Amritsar
  - b. Patiala
  - c. Bhatinda
  - d. Jalandhar
- 

81. The demand rate for a particular item is 12000 units/year. The ordering cost is Rs. 100 per order and the holding cost is Rs. 0.80 per item per month. If no shortages are allowed and the replacement is instantaneous, then the number of orders per year is (+1, -0.33)

- a. 12



---

b. 36

c. 48

d. 24

---

82. Which of the following is the input component(s) to Materials Requirement Planning (MRP) system? (+1, -0.33)

a. Bill of materials

b. Master Production Schedule

c. Inventory status file

d. All of the options

---

83. Cyaniding is carried out at a temperature of \_\_\_\_\_ . (+1, -0.33)

a. 175°C

b. 950°C

c. 500°C

d. 1300°C

---

84. In electrochemical grinding process, the material removal rate is inversely proportional to (+1, -0.33)

a. Total supply current

b. Both density of workpiece material and supply of current

---

c. Density of workpiece material

d. Feed rate of electrode

---

85. Why do particles in liquid water at  $0^{\circ}\text{C}$  have more energy as compared to particles in ice at the same temperature? (+1, -0.33)

a. the particles in water absorb heat energy during the process of conversion from ice to water vapour

b. Because the particles in ice absorb heat energy during the process of conversion from ice to liquid water

c. the particles in water radiate heat energy during the process of conversion from ice to liquid water

d. the particles in water absorb heat energy during the process of conversion from ice to liquid water

---

86. Which of the following states that, "If a body is in equilibrium, under the action of three concurrent forces, each force is proportional to the sine of the angle between the other two forces"? (+1, -0.33)

a. Parallelogram law of forces

b. Varignon's theorem

c. Transmissibility of forces

d. Lami's theorem

---

87. Major purpose of most of the dams around the world is- (+1, -0.33)

- 
- a. Drinking water supply
  - b. All of the options
  - c. Irrigation
  - d. Power generation
- 

88. Which of the following varnishes are prepared by dissolving hardest gums like copal in drying oil and volatile solvents? (+1, -0.33)

- a. Water varnish
  - b. Spirit varnish
  - c. Oil varnish
  - d. Turpentine varnish
- 

89. The ability of a material to resist deformation or deflection under stress is known as- (+1, -0.33)

- a. Toughness
  - b. Mechanical strength
  - c. Ductility
  - d. Stiffness
- 

90. \_\_\_\_\_ is a process for placing a thin phosphate coating on steel. (+1, -0.33)

- a. Parkerizing

- 
- b. Sheradizing
  - c. Galvanization
  - d. Anodizing
- 

91. The distance between the forces acting in the couple is (+1, -0.33)
- a. A finite variable distance
  - b. Infinity
  - c. Always a fixed distance
  - d. Zero
- 

92. Fishbone diagram is also known as \_\_\_\_\_ (+1, -0.33)
- a. Cause-and-effect diagram
  - b. Stratification
  - c. Pareto chart
  - d. Histogram
- 

93. The working cycle of two stroke engine is completed in \_\_\_\_\_ (+1, -0.33)  
revolutions of crank shaft.
- a. Two
  - b. Four
  - c. Three

---

d. One

---

94. Ramsar convention is related to which of the following? (+1, -0.33)

- a. Forests
  - b. Wetlands
  - c. Animal Protection
  - d. Ozone Depletion
- 

95. Steel containing less than 0.15% carbon content is known as- (+1, -0.33)

- a. Medium carbon steel
  - b. Stainless steel
  - c. Dead mild steel
  - d. High carbon steel
- 

96. Which of the following is NOT an angular measuring instrument? (+1, -0.33)

- a. Sine bar
  - b. Bevel Protractor
  - c. Micrometer
  - d. Autocollimator
- 

97. The effective length 'L' of a column hinged at both ends as compared to its (+1, -0.33)

---

actual length 'l' is-

- a.  $L = l/2$
  - b.  $L = l$
  - c.  $L = 2l$
  - d.  $L = 2l^2$
- 

98. What is the maximum font size you can apply for any character in MS Word 2007? (+1, -0.33)

- a. 163
  - b. 1638
  - c. 16038
  - d. None of the above
- 

99. If 1 kg mixture of steam contains 0.8 kg of dry vapor and 0.2 kg of moisture, then the dryness fraction of the steam is (+1, -0.33)

- a. 0.8
  - b. 0.6
  - c. 0.2
  - d. 0.5
- 

100. Which of the following is an example of flow production? (+1, -0.33)

- 
- a. Textiles
  - b. Bridge and dam construction
  - c. Paint shop
  - d. Gas and oil
- 

101. Which of the following Japanese terms in 5S methodology represents the meaning of shine? (+1, -0.33)

- a. Seiri
  - b. Shitsuke
  - c. Seiso
  - d. Seiton
- 

102. Meander drive is a \_\_\_\_\_ shaft mechanism. (+1, -0.33)

- a. Four
  - b. One
  - c. Three
  - d. Two
- 

103. Which of the following elements has the maximum atomic radius? (+1, -0.33)

- a. P
- b. Cl

---

c. Na

d. S

---

104. The horizontal component of tensile force in a wire that makes  $60^\circ$  with horizontal and is carrying a force of 20 kN is (+1, -0.33)

a. 10 kN

b. 18 kN

c. 30 kN

d. 25 kN

---

105. Sigma comparator is a type of \_\_\_\_\_ comparator. (+1, -0.33)

a. Electrical

b. Electronic

c. Mechanical

d. Optical

---

106. Which theory of failure will you use for aluminium components under steady loading? (+1, -0.33)

a. Maximum principal stress theory

b. Maximum shear stress theory

c. Maximum strain energy theory



---

d. Maximum principal strain theory

---

107. To what degree are the edges of optical flats bevelled? (+1, -0.33)

a. 45°

b. 90°

c. 60°

d. 30°

---

108. Which of the following is an extensive property? (+1, -0.33)

a. Melting point

b. Volume

c. Boiling point

d. Density

---

109. The ability of a material to absorb energy in the elastic region is called- (+1, -0.33)

a. Ductility

b. Resilience

c. Toughness

d. Hardness

---

110. Which of the following is a disadvantage of most of the renewable energy (+1, -0.33)

---

sources?

- a. Unreliable supply
  - b. High waste disposal cost
  - c. Highly polluting
  - d. High running cost
- 

111. The moment of inertia of a solid cylinder of mass 'm', radius 'R' and length 'l' about the longitudinal axis or polar axis is- (+1, -0.33)

- a.  $mR^2/2$
  - b.  $mR^2/4$
  - c.  $mR^2/8$
  - d.  $mR^2/6$
- 

112. The term 'grating' in metrology means that (+1, -0.33)

- a. Rulings are more closely spaced, producing a periodic pattern without blank gaps
  - b. Rulings follow a logarithmic scale
  - c. Rulings need not have any pattern
  - d. Rulings are spaced relatively far apart, requiring some type of interpolating device to make accurate settings
- 

113. Which movie won the Best Film award in 63rd Filmfare Awards? (+1, -0.33)

- 
- a. Tumhari Sulu
  - b. Secret Superstar
  - c. Trapped
  - d. Hindi Medium
- 

114. The velocity with which the water approaches a notch is called (+1, -0.33)

- a. Velocity of whirl
  - b. Velocity of approach
  - c. Velocity of flow
  - d. Shear velocity
- 

115. How do the hard disks record information? (+1, -0.33)

- a. Propagation
  - b. Gravitation
  - c. Magnetisation
  - d. Centrifugation
- 

116. In machine lapping, for hard materials, pressure up to \_\_\_\_\_ is applied. (+1, -0.33)

- a.  $0.5 \text{ N/mm}^2$
- b.  $1 \text{ N/mm}^2$

---

c.  $0.05 \text{ N/mm}^2$

d.  $0.02 \text{ N/mm}^2$

---

117. Which of the following is an example of diffuse reflection? (+1, -0.33)

a. Both reflection on mirror and still water

b. Reflection on mirrors

c. Reflection on roadway

d. Reflection on still water

---

118. Pinch effect in welding is the result of (+1, -0.33)

a. Surface tension of the molten metal

b. Electromagnetic forces

c. Expansion of gases in the arc

d. Shielding gases

---

119. Pallet is an example for which operating principle of material handling plan? (+1, -0.33)

a. Flow principle

b. Gravity principle

c. Space utilization principle

d. Unit load principle

---

120. Communication between a computer and a keyboard involves \_\_\_\_\_ transmission. (+1, -0.33)

- a. Automatic
  - b. Half-duplex
  - c. Full-duplex
  - d. Simplex
  - e. Transitive
- 

121. The unit of moment of inertia of mass is- (+1, -0.33)

- a.  $m^2/kg$
  - b.  $kg/m$
  - c.  $kg \cdot m^2$
  - d.  $kg/m^2$
- 

122. Who among the following releases the book 'Mann Ki Baat - A Social Revolution on Radio'? (+1, -0.33)

- a. Arun Jaitley
- b. Piyush Goyal
- c. Amit Shah
- d. Sushma Swaraj

---

---

123. Gantt chart is a type of chart which illustrates the- (+1, -0.33)

- a. Assignable causes of variation in a process
  - b. Inventory status and materials requirement
  - c. Project schedule
  - d. Common causes of variation in a process
- 

124. 'If  $\theta$ ' is angle of projection and 'u' is velocity of projection for a projectile, then its horizontal range is given by- (+1, -0.33)

- a.  $R = (u^2 \sin 2\theta) / g$
  - b.  $R = (u^2 \cos \theta) / g$
  - c.  $R = (u^2 \cos 2\theta) / g$
  - d.  $R = (u^2 \sin \theta) / g$
- 

125. The maximum heat in resistance welding is at the- (+1, -0.33)

- a. Tip of the positive electrode
  - b. Interface between the two plates being joined
  - c. Tip of the negative electrode
  - d. Top surface of the plate at the time of electric contact with the electrode
-

---

126. Which part of the solar cooker is responsible for the greenhouse effect? (+1, -0.33)

- a. Coating with black colour inside the box
  - b. Mirror
  - c. Glass sheet
  - d. Outer cover of the solar cooker
- 

127. The lower critical point for all steels is (+1, -0.33)

- a. 723°C
  - b. 913°C
  - c. 600°C
  - d. 800°C
- 

128. Which of the following is the most common substrate material for hot-dip metallic coating? (+1, -0.33)

- a. Steel
  - b. Aluminium
  - c. Zinc
  - d. Terene
- 

129. What is the value of the acceleration due to gravity (g) of Earth? (+1, -0.33)

- a.  $3.8 \text{ m s}^{-2}$

---

b.  $5.4 \text{ m s}^{-2}$

c.  $6.8 \text{ m s}^{-2}$

d.  $9.8 \text{ m s}^{-2}$

---

130. Otto cycle is a constant \_\_\_\_\_ cycle. (+1, -0.33)

a. Temperature

b. Entropy

c. Pressure

d. Volume

---

131. In an air standard Otto cycle, the compression ratio is 7. Find the cycle efficiency (+1, -0.33)

a. 54%

b. 38%

c. 71%

d. 80%

---

132. Limiting force of friction is the (+1, -0.33)

a. Ratio of limiting friction and normal reaction

b. Friction force acting when the body is just about to move

c. Tangent of angle between normal reaction and the resultant of



---

normal reaction and limiting friction

d. Friction force acting when the body is in motion

---

133. Which computer application scans texts and converts into readable form in computer? (+1, -0.33)

a. Optical Scanner Reader

b. Optical Character Recognition

c. Optical Marker Recognition

d. Optical Character Evaluator

---

134. In BCD code, maximum possible characters set size is- (+1, -0.33)

a. Character set of 94

b. Character set of 84

c. Character set of 64

d. Character set of 104

---

135. A stream line and an equipotential line in a two dimensional inviscid flow field- (+1, -0.33)

a. Are perpendicular to each other

b. Intersect at an acute angle

c. Are parallel to each other

---

d. Are identical

---

136. The Moment of Inertia of a circular area of diameter 'd' about its diameter axis is- (+1, -0.33)

a.  $\pi d^2/64$

b.  $\pi d^3/36$

c.  $\pi d^4/64$

d.  $\pi d^2/36$

---

137. A radius gauge is also known as- (+1, -0.33)

a. Snap gauge

b. Feeler gauge

c. Fillet gauge

d. Slip gauge

---

138. Which of the following is a junction of side and end cutting edge in single point cutting tool? (+1, -0.33)

a. Base

b. Flank

c. Heel

d. Nose

---

---

139. Water decomposes in presence of electricity into H and O , this process is called (+1, -0.33)

- a. Photochemical decomposition
- b. Electrolysis
- c. Thermal decomposition
- d. Displacement Reaction

---

140. The malleability is the property of a material by virtue of which a material- (+1, -0.33)

- a. Can be rolled or hammered into thin sheets
- b. Regains its shape and size after the removal of external forces
- c. Retains the deformation produced under load permanently
- d. Can be drawn into wires with the application of a tensile force

---

141. Shear thickening fluid is also known as- (+1, -0.33)

- a. Pseudoplastic
- b. Dilatant
- c. Thixotropic
- d. Rheopectic

---

142. The process of draining steam for heating the feed-water is known as (+1, -0.33)

- 
- a. Bleeding
  - b. Governing
  - c. Cooling
  - d. Reheating of steam
- 

143. A single unit which is composed of small group of bits is known as- (+1, -0.33)

- a. Bug
  - b. Bit
  - c. Byte
  - d. Flag
- 

144. Funds belonging to the Government of India are kept in- (+1, -0.33)

- a. Public Account of India
  - b. Consolidated fund of India
  - c. All of the options
  - d. Contingency Fund of India
- 

145. Where is India's the first oceanarium being set up? (+1, -0.33)

- a. Vishakhapatnam
- b. Mumbai

---

c. Kochi

d. Goa

---

146. Johanssen Gauges are otherwise known as- (+1, -0.33)

a. Radius gauges

b. Snap gauges

c. Slip gauges

d. Feeler gauges

---

147. What is the magnitude of the maximum disturbance in the medium on either side of the mean value called? (+1, -0.33)

a. Oscillation

b. Amplitude

c. Frequency

d. Wavelength

---

148. The square root of the ratio of the inertia force due to flow to the elastic force of fluid is known as- (+1, -0.33)

a. Mach number

b. Strouhal number

c. Froude number

---

d. Reynolds number

---

149. Which of the following phase is obtained as the end product, after complete heat treatment cycle in austempering process? (+1, -0.33)

- a. Bainite
  - b. Martensite
  - c. Austenite
  - d. Pearlite
- 

150. The complete resistance spot weld cycle has been divided into \_ \_ \_ \_ parts. (+1, -0.33)

- a. Four
- b. Five
- c. Three
- d. Two

---

## Answers

1. Answer: a

**Explanation:**

The correct answer is Jai Hind.

- The slogan Jai Hind (Long Live India) was printed on the top right side in the stamp.

### Important Points

- The first stamp of independent India was issued on 21 November 1947 .
- Depicts the Indian tricolour flying high in the clouds, with the slogan Jai Hind (Long Live India) on the top right.
- The stamp had a blue background and was valued at three and one-half annas.

### Key Points

- World Post Day: 9<sup>th</sup> of October.
- Mahatma Gandhi was the first person whose picture was depicted on free India's stamp in 1948.
- India was the first country in the Commonwealth to issue airmail stamps .
- The Postal Index Number or PIN code is a six-digit unique code of post-office numbering introduced on 15 August, 1972 by Shriram Bhikaji Velankar.

---

2. Answer: d

**Explanation:**

Explanation:

Mach number

Mach number is defined as the ratio of inertia force to elastic force.

$$M = \sqrt{\frac{\text{Inertia force}}{\text{Elastic force}}} = \sqrt{\frac{\rho AV^2}{KA}} = \sqrt{\frac{V^2}{\frac{K}{\rho}}} = \frac{V}{\sqrt{\frac{K}{\rho}}} = \frac{V}{C} \quad \left\{ \sqrt{\frac{K}{\rho}} = C = \text{Velocity of sound} \right\}$$

$$M = \frac{\text{Velocity of body moving in fluid}}{\text{velocity of sound in fluid}}$$

For the compressible fluid flow, Mach number is an important dimensionless parameter. On the basis of the Mach number, the flow is defined.

Mach Number	Type of flow
$M < 0.8$	Sub-sonic flow
$0.8 < M < 1.3$	Trans-sonic
$M = 1$	Sonic flow
$1.3 < M < 5$	Super-sonic flow
$M > 5$	Hypersonic flow

### Important Points

Other important dimensionless numbers are described in the table below



Reynold's number	$R_e = \frac{\text{inertia force}}{\text{viscous force}} = \frac{\rho V L}{\mu}$
Froude Number	$F_r = \sqrt{\frac{\text{inertia force}}{\text{gravitation force}}} = \frac{V}{\sqrt{Lg}}$
Euler number	$E_u = \sqrt{\frac{\text{inertia force}}{\text{pressure force}}} = \frac{V}{\sqrt{P/\rho}}$
Weber Number	$W_e = \sqrt{\frac{\text{inertia force}}{\text{surface tension}}} = \frac{V}{\sqrt{\sigma/\rho L}}$

### 3. Answer: c

#### Explanation:

##### Explanation:-

##### Clearance angle ( $\alpha$ ):

- The angle of inclination of clearance or flank surface from the finished surface.
- The clearance angle is essentially provided to avoid rubbing of the tool (flank) with the machined surface which causes loss of energy and damages to both the tool and the job surface.
- Clearance angle is a must and must be positive ( $3^\circ - 15^\circ$ ) depending upon tool-work materials.

##### Important Points



- 
- Operating expenses are the costs involved in running the day-to-day operations of a company
  - Inventory is the term for the goods available for sale and raw materials used to produce goods available for sale.
  - Takt time is the average time between the start of production of one unit and the start of production of the next unit.
- 

5. Answer: c

**Explanation:**

Explanation:-

- **Porosity** is defined as cavity-type discontinuities formed by gas entrapment during solidification.
- Porosity is caused by gases that are present in the molten weld.
- These gases may be trapped and form bobbles or gas pockets as the weld solidify cause porosity are dirty base material, moisture.
- Causes of porosity:
  - The presence of moisture.
  - Improper gas shield.
  - Incorrect surface treatment.
  - Use of too high gas flow.
  - Contaminated surface.
  - Presence of rust, paint, grease or oil.

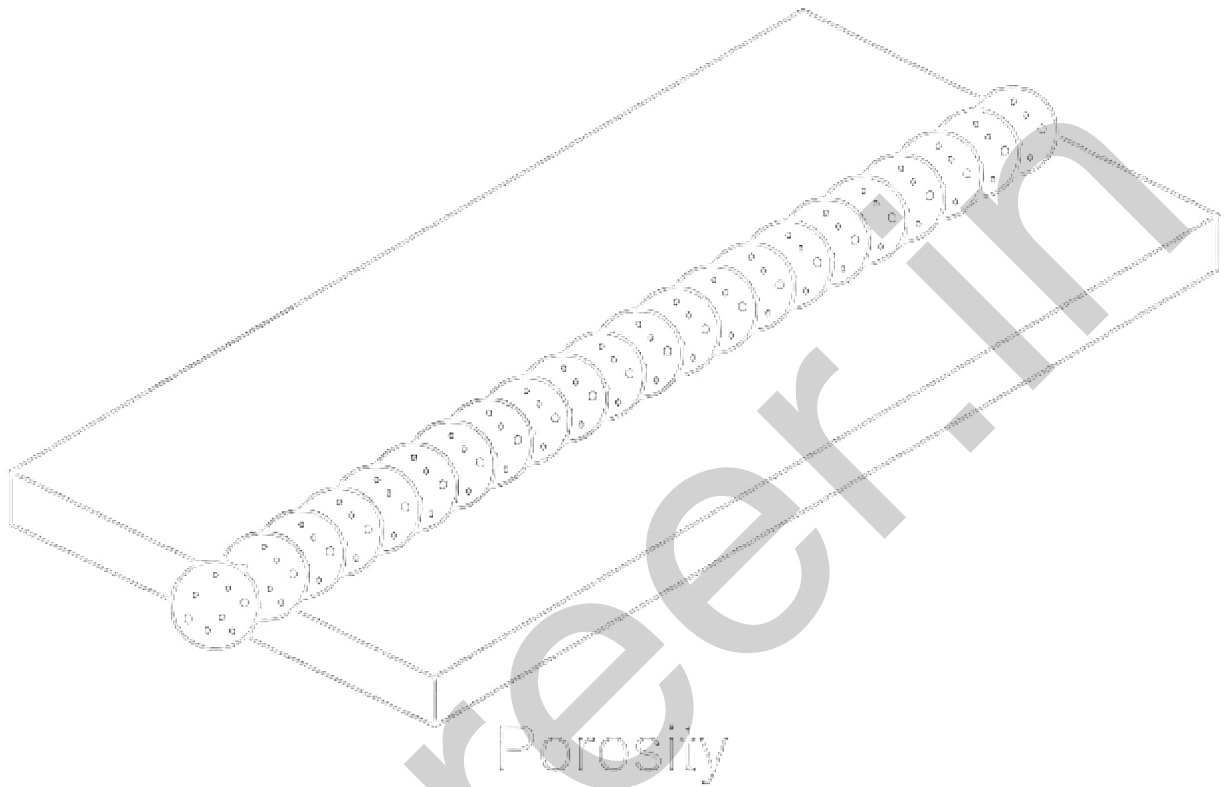

### Important Points

- When the porosity is seen in the weld face, it is also referred to as "**pit**".
- When the porosity is detected, by fracture or radiograph tests, as a sub-surfaced pore that does not extend to the weld face, it is also referred to as "**blowhole**."
- Weld Crack - The most serious type of welding defect is a weld crack and it's not accepted almost by all standards in the industry. It can appear on the surface, in the weld metal or the area affected by the intense heat.

---

6. Answer: c

Explanation:

Explanation:

---

The Vernier principle states that two different scales are constructed on a single known length of line and the difference between them is taken for fine measurements.

Determining the least count of Vernier callipers:

In the Vernier calliper shown in Fig the main scale divisions (9 mm) are divided into 10 equal parts in the Vernier scale. i.e.

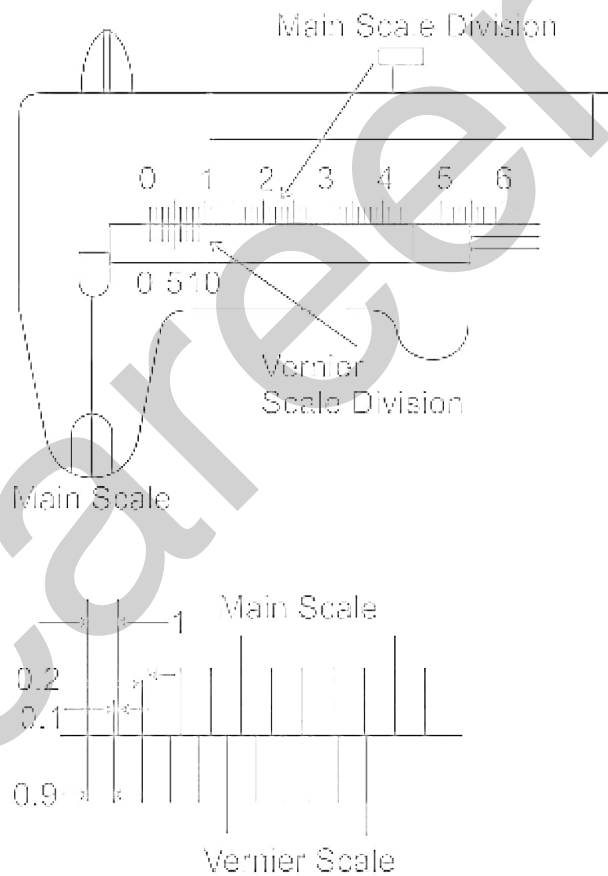

One main scale division (MSD) = 1 mm

One Vernier scale division (VSD) =  $\frac{9}{10}$  mm

Least count = 1 MSD - 1 VSD

= 1 mm -  $\frac{9}{10}$  mm = 0.1 mm

The difference between one MSD and one VSD = 0.1 mm

---

---

7. Answer: d

**Explanation:**

Explanation:-

**High-Velocity Oxygen Fuel (HVOF)** coating is a thermal spray coating process used to improve or restore a component's surface properties or dimensions, thus extending equipment life by significantly increasing erosion and wear resistance, and corrosion protection.

In the HVOF process, the Kinetic energy of the particle is more imp than temperature.

---

8. Answer: a

**Explanation:**

Explanation:-

**Sine Bar**

- When a reference for a non-square angle is required, a sine bar can be used.
- Basically, a sine bar is a bar of known length. When gauge blocks are placed under one end, the sine bar will tilt to a specific angle.
- Knowing the height differential of the two rollers in alignment with the workpiece, the angle can be calculated using the sine formula.
- A sine bar is specified by the distance between the centre of the two rollers, i.e. 100 mm, 200 mm, & 300 mm. the various part of sine bar is hardened before grinding & lapping.

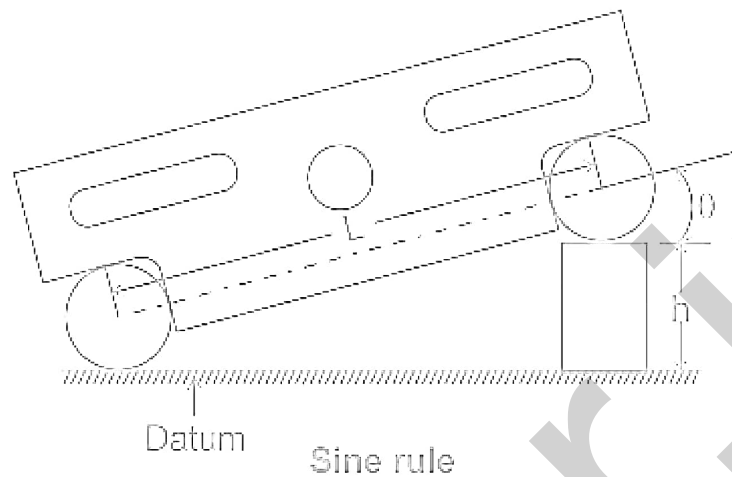

$$\sin \theta = \frac{h}{L}$$

Here,

L = centre distance between two rollers, H = height of the gauge block

Calculation:-

Given:-

$$\theta = 30^\circ, L = 5.00''$$

$$\sin \theta = \frac{H}{L}$$

$$H = L \times \sin \theta$$

$$H = 5.00'' \times \sin 30^\circ$$

$$H = 2.500''$$

9. Answer: d

**Explanation:**

Explanation:-

The lead screw is used to move the carriage automatically during threading.

- 
- **The lead screw** is a long threaded shaft used as a master screw.
  - It is brought into operation during thread cutting to move the carriage to a calculated distance
  - Mostly lead screws are acme threaded.

### Important Points

**The bed** is mounted on the legs of the lathe which are bolted to the floor.

- It is made of cast iron and its top surface is machined accurately and precisely.

**The feed** rod is placed parallel to the lead screw on the front side of the bed.

- It is a long shaft which has a keyway along its length,

**The carriage handwheel** is used to manually position and/or hand feed the carriage in the longitudinal or axis.

---

10. **Answer: d**

**Explanation:**

Concept:

- A control volume is a fixed, identifiable region in space through which fluid flows.
- The boundary of the control volume is called a control surface.
- Types of System

Control Mass System (Closed System)



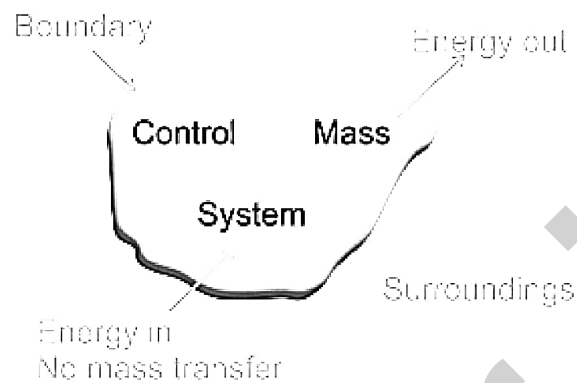

- It is a system of fixed mass with a fixed identity
- This type of system is usually referred to as "closed system"
- There is no mass transfer across the system boundary
- Energy transfer may take place into or out of the system

#### Control Volume System (Open System)

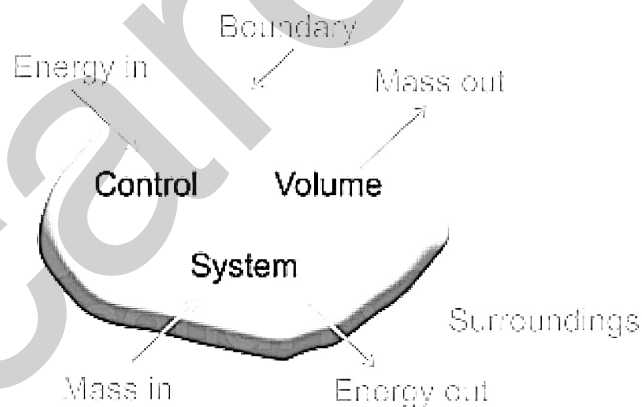

- It is a system of fixed volume
- This type of system is usually referred to as "open system" or a "control volume"
- Mass transfer can take place across a control volume
- Energy transfer may also occur into or out of the system
- A control volume can be seen as a fixed region across which mass and energy transfers are studied
- Control Surface - It is the boundary of a control volume across which the transfer of both mass and energy takes place
- The mass of a control volume (open system) may or may not be fixed

---

Most of the engineering devices, in general, represent an open system or control volume.

---

11. Answer: d

**Explanation:**

Explanation:-

**Lower critical temperature (point)  $A_1$**  is the temperature of the austenite-to-pearlite eutectoid transformation. Below this temperature austenite does not exist.

**Critical temperatures**

- **Upper critical temperature (point)  $A_3$**  is the temperature, below which ferrite starts to form as a result of ejection from austenite in the hypoeutectoid alloys.
- **Upper critical temperature (point)  $A_{CM}$**  is the temperature, below which cementite starts to form as a result of ejection from austenite in the hypereutectoid alloys.
- **Magnetic transformation temperature  $A_2$**  is the temperature below which  $\alpha$ -ferrite is ferromagnetic .

Phase compositions of the iron-carbon alloys at room temperature

- **Hypoeutectoid steels** (carbon content from 0 to 0.83%) consist of primary (pro eutectoid) ferrite (according to the curve  $A_3$ ) and pearlite.
- **Eutectoid steel** (carbon content 0.83%) entirely consists of pearlite.
- **Hypereutectoid steels** (carbon content from 0.83 to 2.06%) consist of primary (pro eutectoid) cementite (according to the curve  $A_{CM}$ ) and pearlite.
- **Cast irons** (carbon content from 2.06% to 4.3%) consist of pro eutectoid cementite  $C_2$  ejected from austenite according to the curve  $A_{CM}$ , pearlite, and transformed ledeburite (ledeburite in which austenite transformed to pearlite).
- The point of **decalescence** occurs at the temp where the pearlite changes to austenite as the steel is heated. The point of decallescenes occurs as the temperature is rising

- The point of **recalescence** occurs as the steel is cooled slowly the austenite returns to pearlite. The point of recalescences occurs as the temperature is falling.

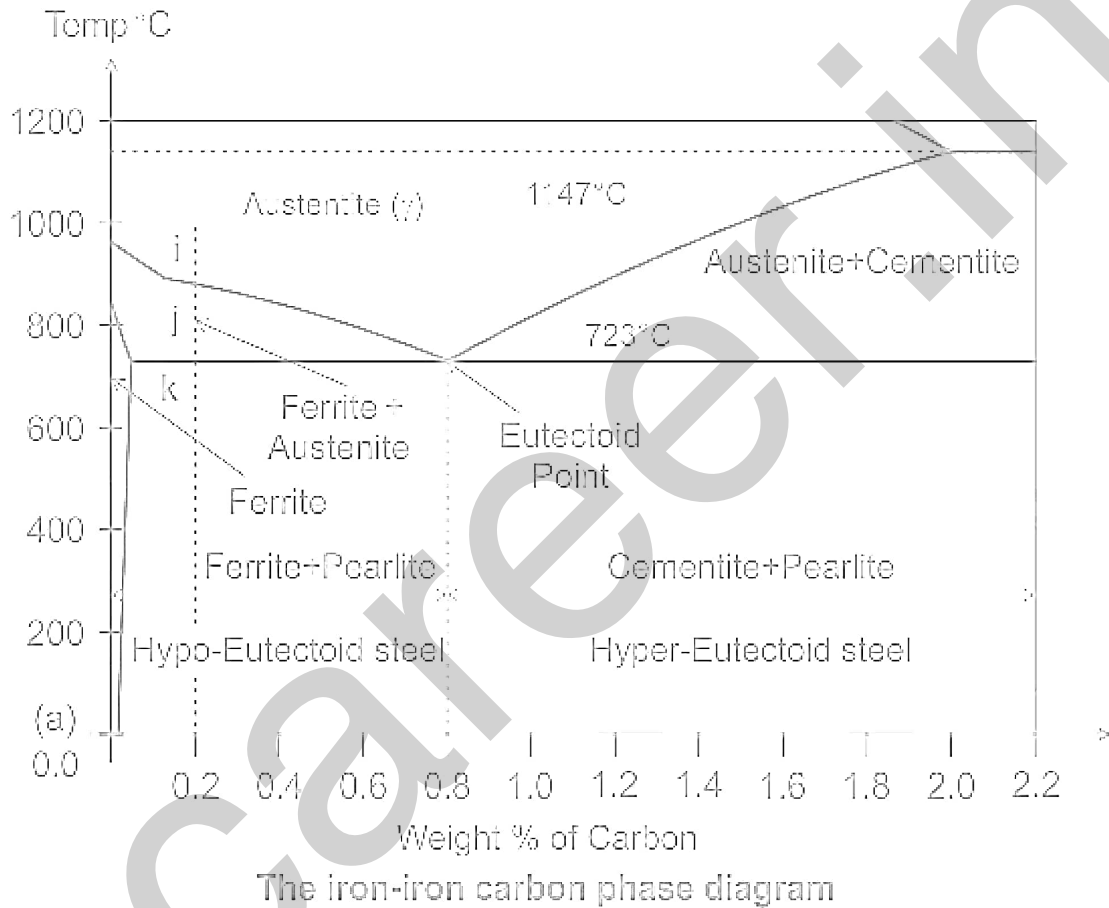

12. Answer: c

**Explanation:**

Explanation:

Cutting tools may be classified according to the number of major cutting edges (points) involved as follows:

- Single point Tools (One dominant cutting edge): e.g., **turning tools**, shaping, cutoff/parting tool, planning and slotting tools and boring tools

- 
- **Multiple Cutting Edge Tools** (More than one cutting edge): e.g., Drill, milling cutters, broaching tools, hobs, gear shaping cutters, grinding wheel, Hacksaw Blade.

## Turning

- Turning is an operation which reduces the diameter of a workpiece to a desired dimension and length of the workpiece remains the same.
- Turning is done with the help of single-point cutting tool.

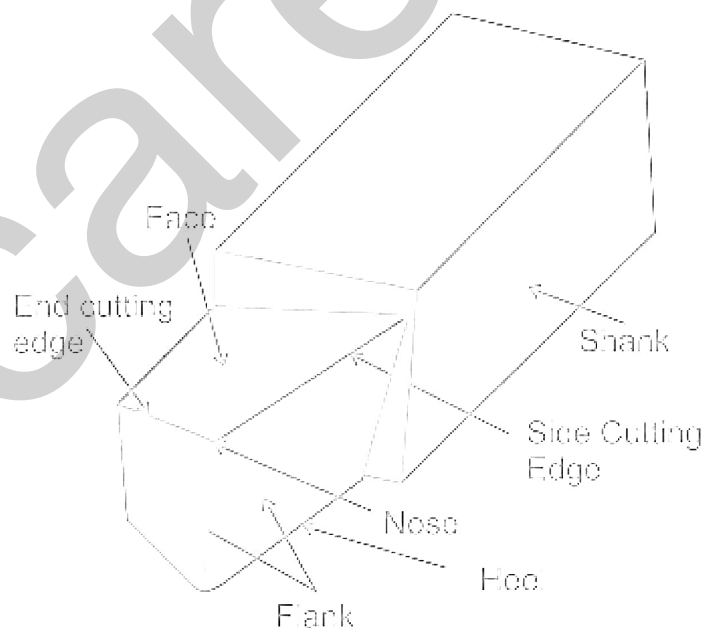
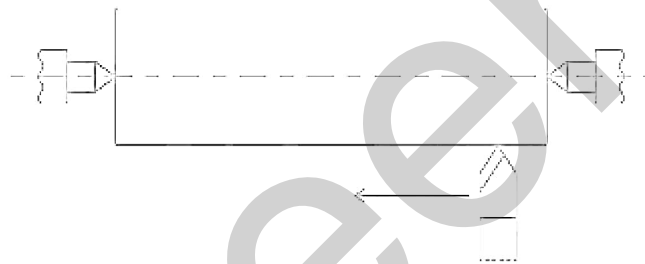

### Important Points

Milling is a process of producing flat and complex shapes with the use of a **multi-point** (or multi-tooth) cutting tool.

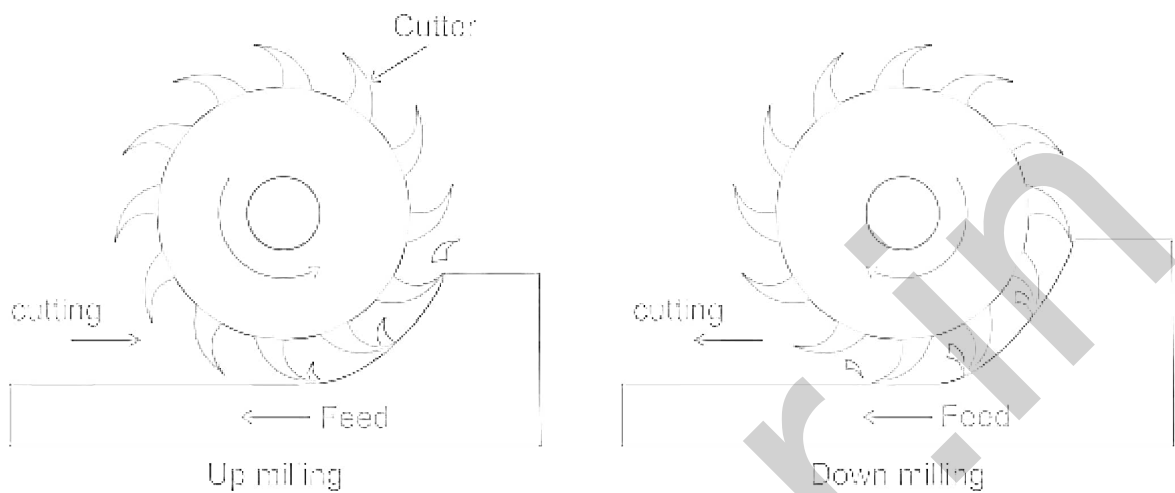

A drill is a **multipoint cutting tool** used for making the cylindrical holes of definite diameters.

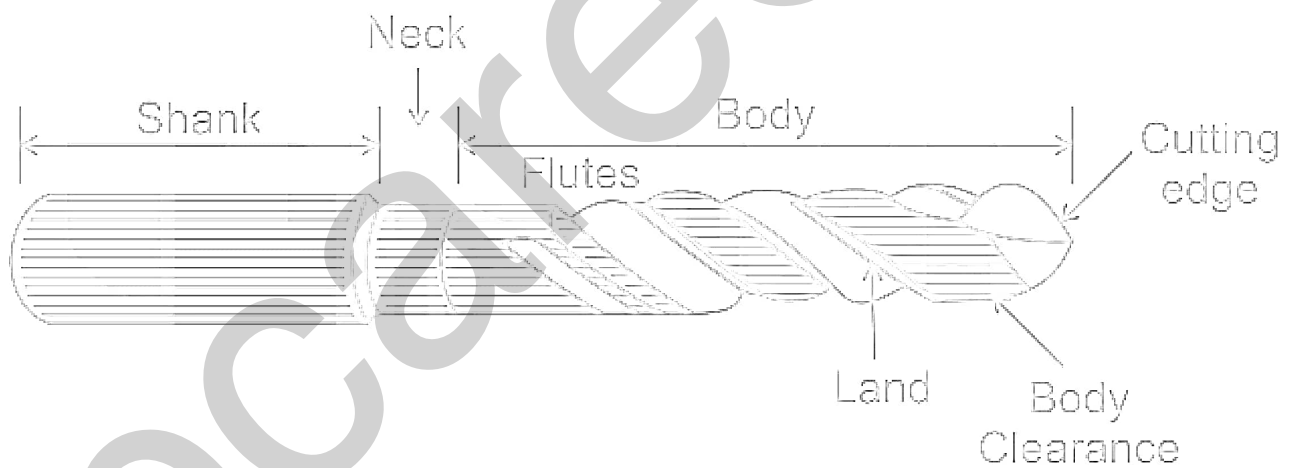

**Broaching** is a machining process for removal of a layer of material of desired width and depth usually in one stroke by a slender rod or bar type cutter having a **series of cutting edges** with gradually increased protrusion.

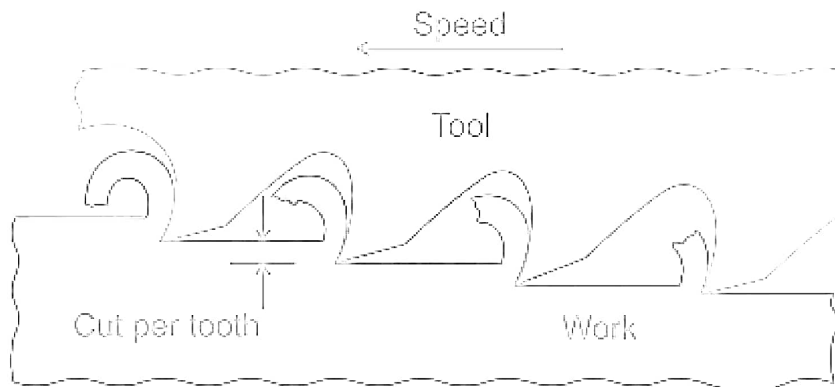

---

---

13. Answer: b

**Explanation:**

Concept:

If Rod is free to expand,

Free elongation  $\Delta L = L\alpha\Delta T$

$$\therefore \Delta L/L = \alpha\Delta T$$

Here **rod is fixed at both ends** so strain will be zero but due to restriction given by fixed ends, there will be reaction force at the end.

That reaction force per unit area is known as thermal stress.

It is given by-

$$\sigma = E\epsilon$$

$$\text{or, } \sigma = E(\Delta L/L) = E\alpha(\Delta T)$$

Since rod is fixed at both ends, so thermal strain will be zero but there will be thermal stress.

---

14. Answer: d

**Explanation:**

Grain size or Grit size:

- It indicates the size of abrasive particles. i.e. Size of abrasives = 1/ Grain Size Number (GSN)

- 
- When the GSN  $> 600$ , size of the abrasive particles becomes very very small and it cannot act like a cutting tool, therefore MRR is less.
  - When GSN  $< 600$ , actual size of abrasive is increasing, the chip size is increasing and MRR is increasing.
  - As the GSN is reducing or size of abrasive is increasing, the MRR is increasing first and then reducing.
  - The grain size is selected based on the surface finish required on the workpiece i.e. for rough grinding, coarse or medium grain size is selected and for finished grinding fine or very fine grain size will be selected.
  - 10 - 24 = coarse, 30 - 60 = Medium, 80 - 180 = Fine, 220 - 600 = very fine
- 

15. Answer: a

**Explanation:**

The correct answer is Waxing phase of the moon.

**Important Points**

- The revolution of the Moon around the Earth makes the Moon appear as if it is changing shape in the sky.
  - The "phases" of the Moon are caused by the different angles from which we see the bright part of the Moon's surface.
- There are four major shapes.
  - **New Moon:** The lighted side of the Moon faces away from the Earth. This means that the Sun, Earth, and Moon are almost in a straight line, with the Moon in between the Sun and the Earth. The Moon that we see looks very dark.
  - **First Quarter:** The right half of the Moon appears lighted and the left side of the Moon appears dark. During the time between the New Moon and the First Quarter Moon, the part of the Moon that appears lighted gets larger and larger every day, and will continue to grow until the Full Moon.
  - **Full Moon:** The lighted side of the Moon faces the Earth. This means that the Earth, Sun, and Moon are nearly in a straight line, with the Earth in the

---

middle. The Moon that we see is very bright from the sunlight reflecting off it.

- **Last Quarter: Sometimes called Third Quarter. The left half of the Moon appears lighted, and the right side of the Moon appears dark. During the time between the Full Moon and the Last Quarter Moon, the part of the Moon that appears lighted gets smaller and smaller every day. It will continue to shrink until the New Moon, when the cycle starts all over again.**
  - When the shadow is shrinking and progressing towards a full moon, the moon phase is waxing.
  - When the shadow is progressing towards a new moon, the moon phase is waning.
- 

16. Answer: a

**Explanation:**

The correct answer is Restart.

Important Points



Restart	<ul style="list-style-type: none"> <li>• To reboot is to restart a computer and reload the operating system.</li> <li>• The most common reasons to restart are because the installation of new software or hardware requires it, or because applications are not responding for some reason.</li> </ul>
Sleep	<ul style="list-style-type: none"> <li>• Sleep is a low power mode for electronic devices or components in computer.</li> <li>• Sleep mode suspend to RAM .</li> <li>• It turning off computer display when it is not use.</li> </ul>
Shut Down	<ul style="list-style-type: none"> <li>• It is power off a computer .</li> </ul>
Hibernate	<ul style="list-style-type: none"> <li>• It suspend to hard disk .</li> <li>• It is a power-saving mode but differs from sleep mode because it done with computer data .</li> </ul>

17. Answer: d

**Explanation:**

Explanation:

- The instrument for routine monitoring of total ozone was developed by **Gordon M. B. Dobson** .
- A Dobson unit is the most basic measure used in ozone research.
- One Dobson Unit (DU) is defined to be 0.01 mm thickness at STP (standard temperature and pressure).
- **Ozone layer thickness is expressed in terms of Dobson units**, which measure what its physical thickness would be if compressed in the Earth's atmosphere.

- 
- In those terms, it's very thin indeed. A normal range is 300 to 500 Dobson units.
- 

**18. Answer: b**

**Explanation:**

**Explanation:**

- Indian Cricket Captain Virat Kohli has been named as International Cricket Council Cricketer of the Year 2017.
  - He was also named the **ICC ODI Player of the Year & recipient of Sir Garfield Sobers Trophy of the Year 2017.**
  - Kohli had an outstanding year in the 50-over format where he scored 6 centuries at an astonishing average of 76.84.
  - He has also been named the captain of Men's ODI & Test Teams of the Year.
- 

**19. Answer: c**

**Explanation:**

**Explanation:-**

Concentration indicates the amount of Superabrasive grit in a grinding wheel.

**Superabrasives**

- Superabrasives make up a special category of bonded abrasives designed for grinding the hardest, most challenging work materials.
- These materials offer extreme hardness, but they are more expensive than conventional abrasives (silicon carbide and aluminum oxide).
- The concentration of a Superabrasive layer depth by the abrasive concentration and the addition of the super abrasive wheel is the amount of abrasive in the abrasive layer.

- 
- Because of the high cost of super abrasives, a thin layer of a grinding wheel may be attached to a core material so that only that layer of a grinding wheel may be attached to a core material so that only the outer layer is useable of super abrasives

### Important Points

- **High concentrations (100-200 )** are suitable for mass production of parts and tools made from tungsten carbide, HSS, ceramic products, creep-feed, and profile grinding.
  - **Medium concentrations (75-125)** used for tool maintenance, resharpening, and internal grinding.
  - **Low concentrations (25-100)** are suitable for cutting discs, honing, dressing, drilling, and general uses.
- 

20. Answer: b

### Explanation:

#### Concept:

- Silicon steel is an important soft magnetic material is used nowadays.
- It is a ferritic alloy of iron and silicon that has magnetic properties which makes it useful in the electrical industry (generators, motors, and transformers).
- In Si-steel, the Si is added in Fe up to 5%
- The effects of adding silicon are:
  - Permeability increases
  - Resistivity increases
  - Hysteresis losses decrease
- As Si is semi-conductor and Fe is a conductor so resistivity  $\rho_{Fe} < \rho_{Si}$ .
- As resistivity increases the eddy current loss decreases. Hence silicon steel is used in electrical machines.
- The earlier magnetic material used was iron but it contains many impurities. So silicon is added to steel to improve its soundness, i.e. free from defects, decays, or damages.

---

---

21. Answer: b

**Explanation:**

Explanation:-

The stress is given as,  $Stress = \frac{Load}{Area}$

where, stress is the ratio of ultimate stress to the factor of safety, i.e. Working stress =  $\frac{Ultimate\ stress}{Factor\ of\ safety}$

Calculations:-

Given:-

Axial load  $P = 200000$  kg, Ultimate stress  $\sigma_u = 4800$  kg/cm<sup>2</sup>, Factor of safety  $n = 4$

Now,

$$Working\ stress = \frac{Ultimate\ stress}{Factor\ of\ safety}$$

$$Working\ stress = \frac{4800}{4}$$

$$Working\ stress = 1200\ kg/cm^2$$

$$Stress = \frac{Load}{Area}$$

$$Area = \frac{load}{working\ stress}$$

$$A = \frac{200000}{1200} = 166.66$$

$$A = 166.66\ cm^2$$

---

22. Answer: b

---

## Explanation:

### Explanation:

- Paramparagat Krishi Vikas Yojana has been formulated to promote Organic Farming.
- The objective of this scheme is to reduce the dependency on agro-chemicals and fertilizers.
- It will be implemented in a cluster approach.
- It will focus on the optimal utilization of natural resources for input production.
- Paramparagat Krishi Vikas Yojana (PKVY) is under the National Mission for Sustainable Agriculture (NMSA).
- NMSA mission is covering other schemes like-
  - Soil and Land Use Survey of India (SLUSI)
  - Rainfed Area Development (RAD)
  - Sub Mission on Agro-Forestry (SMAF)
  - National Rainfed Area Authority (NRAA)
  - Mission Organic Value Chain Development in North Eastern Region (MOVCDNER)
  - National Centre of Organic Farming (NCOF)
  - Central Fertilizer Quality Control and Training Institute (CFQC&TI)

---

## 23. Answer: b

### Explanation:

#### Concept:

#### The angle of limiting friction:

Limiting Angle of Friction is defined as the angle which the resultant reaction (R) makes with the normal reaction (R<sub>N</sub>).

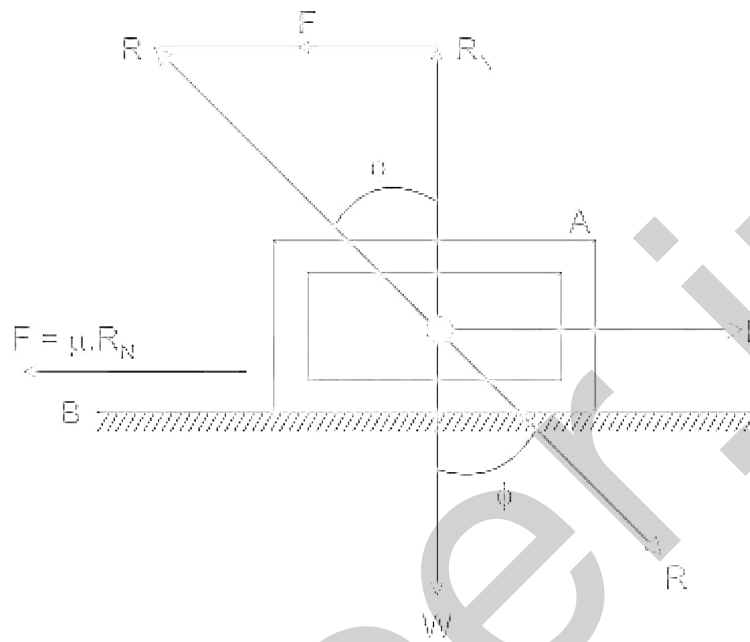

In the limiting case, when the body just begins to move, it is in equilibrium under the action of the following three forces:

1. Weight of the body ( $W$ ),
2. Applied horizontal force ( $P$ ), and
3. Reaction ( $R$ ) between the body A and the plane B.

The reaction  $R$  must, therefore, be equal and opposite to the resultant of  $W$  and  $P$  and will be inclined at an angle ( $\phi$ ) to the normal reaction ( $R_N$ ). This angle  $\phi$  is called the limiting angle of friction or simply angle of friction.

$$\phi = \tan^{-1} \left( \frac{F}{R_N} \right) = \tan^{-1} (\mu)$$

### Important Points

Angle of Repose ( $\alpha$ )

The angle of repose or angle of sliding  $\alpha$  is defined as the minimum angle of inclination of a plane with the horizontal such that a body placed on the plane just begins to slide down.

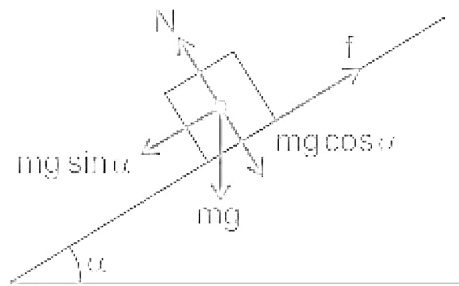

### Angle of Friction ( $\theta$ )

The angle of friction between any two surfaces in contact is defined as the angle which the resultant of the force of limiting friction  $F_{lim}$  and normal reaction  $N$  makes with the direction of normal reaction  $N$ .

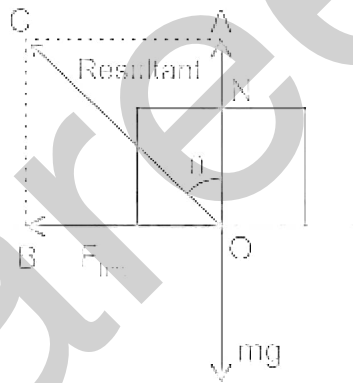

24. Answer: a

### Explanation:

#### Explanation:

- Among the all given options except lead, all metals are usually preferred as a flux for soldering applications.
- Soldering is the process by which metallic materials are joined with the help of another liquified metal (solder).
- All metal rust to some extent, when exposed to the atmosphere because of oxidation. The layer of the rust must be removed before soldering. For this, a chemical compound applied to the joint is called flux.

---

Different types of fluxes are given below

Inorganic fluxes:

- Hydrochloric acid : Concentrated hydrochloric acid is a liquid that fumes when it comes into contact with air. It is used as a flux for sheet metals of zinc-iron or galvanized sheets. This is also known as muriatic acid.
- Zinc chlorides: Zinc chlorides are known as killed spirits. It is mainly used for soldering copper, brass, and tin sheets.
- Ammonium chloride or Sal-Ammoniac : It is a solid white crystalline substance used when soldering copper, brass, iron, and steel (cast iron sheets).
- Phosphoric acid: It is mainly used as a flux for stainless steel.
- Borax: It is used in various household laundry and cleaning products. A mixture of borax and ammonium chloride is used as a flux when welding iron and steel. Borax is also used mixed with water as a flux when soldering jewelry metals such as gold or silver.

Organic fluxes:

- Resin: It is used for soldering copper, brass, bronze, tin plate, cadmium, nickel, silver, and some alloys of these metals.
- Tallow: It is a form of animal fat. It is used when soldering lead, brass, and electrical joints.

---

25. Answer: d

Explanation:

Explanation:

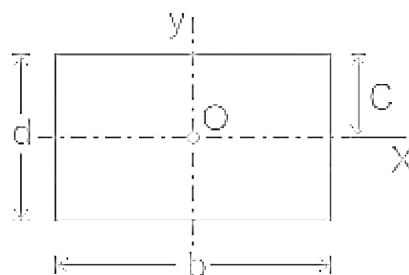



---

Moment of inertia of the rectangular section about X-X axis passing through the C.G. of the section (parallel to width):

$$I_{xx} = \frac{bd^3}{12}$$

Moment of inertia of the rectangular section about Y-Y axis passing through the C.G. of the section (parallel to depth):

$$I_{yy} = \frac{db^3}{12}$$

---

26. Answer: c

Explanation:

Concept:

Designation of Grinding Wheel:

Prefix	Grain Type	Grain Size	Grade	Wheel Structure	Bond Type	Suffix
--------	------------	------------	-------	-----------------	-----------	--------

**Prefix / Suffix:** These are the **secret codes used by the manufacturers** to represent the wheel by its size and shapes respectively.

**Type of Abrasives / Grain type:**

- It indicates materials used for the manufacturing of abrasive particles.
- Out of the abrasives B<sub>4</sub>C is giving the poor performance during machining and diamond is very costly, therefore Al<sub>2</sub>O<sub>3</sub> or SiC are the most commonly used abrasives in the grinding wheel.
- Al<sub>2</sub>O<sub>3</sub> soft and tougher than the SiC whereas SiC will be hard and brittle than Al<sub>2</sub>O<sub>3</sub>
- The type of abrasive is selected based on the mechanical properties of workpiece material i.e. for machining of soft and ductile workpieces, Al<sub>2</sub>O<sub>3</sub> and machining of hard and brittle workpiece SiC will be used.
- A - Al<sub>2</sub>O<sub>3</sub>, B - B<sub>4</sub>C, C - SiC, D - Diamond

---

### Grain size or Grit size:

- It indicates the size of abrasive particles.
- **i.e. Size of abrasives =  $1/\text{Grain Size Number (GSN)}$**
- when the **GSN > 600**, the size of the abrasive particles becomes very very small and it cannot act as a cutting tool, therefore MRR is less.
- When **GSN < 600**, the actual size of the abrasive is increasing, the chip size is increasing and MRR is increasing.
- As the GSN is reducing or the size of the abrasive is increasing, the MRR is increasing first and then reducing.
- The **grain size is selected based on the surface finish** required on the workpiece i.e. for a **rough grinding, coarse or medium grain size** is selected and for **finished grinding fine or very fine grain size** will be selected.
- 10 - 24 = coarse, 30 - 60 = Medium, 80 - 180 = Fine, 220 - 600 = very fine

### Grades of Grinding Wheel:

- It **indicates the hardness of the grinding wheel.**
- The grade of the grinding wheel is selected based on the mechanical properties of the workpiece material.
- The soft wheel is used for grinding of hard workpiece because the rubbing forces induced by the blunt abrasive particle i.e. the self-sharpening is taking place and no dressing is required.
- Hard wheels are used for grinding of the soft workpiece, the abrasive particle will be effectively utilized so that at the end of effective utilization the dressing will be carried for resharping of the grinding wheel.
- A - H = Soft, I - P = Medium, Q - Z = Hard

### Structure:

- The structure is indicating the **average gap between the two consecutive abrasive particles**.
- As the average gap is **large**, the **number of abrasive particle presents per unit area will be small** hence it is called the **open structure**.
- The structure of a grinding wheel can be varied by varying **the % of abrasive particles** and bonding material in the manufacturing of a grinding wheel. i.e.

---

when **higher % of abrasives** and **lower % of bonding material** is used in manufacturing it produces **the dense structure** and vice versa.

- 0 - 7 = Dense, 8 - 16 = Open

**Bonds:**

- Bond indicates the **bonding material** used for the manufacturing of the grinding wheel.
- Out of the different bonding materials, **vitrified is the most commonly used** bonding material because it gives **higher bonding strength, high temperature withstanding capability, and high thermal conductivity**.
- For the manufacturing of **flexible grinding wheels** also called a buffing wheel, **shellac or rubber can be used as the bonding material**.
- V - Vitrified, B - Bakelite, S - Silicate, E - Shellac, R - Rubber

---

27. Answer: d

**Explanation:**

Explanation:

There are three different types of oxy-acetylene flames:

Neutral flames: When oxygen acetylene ratio is almost equal, i.e. 1 : 1

Oxidizing flame: When the oxygen is greater than the fuel gas.

Carburising flame: When the fuel gas is greater than the oxygen.

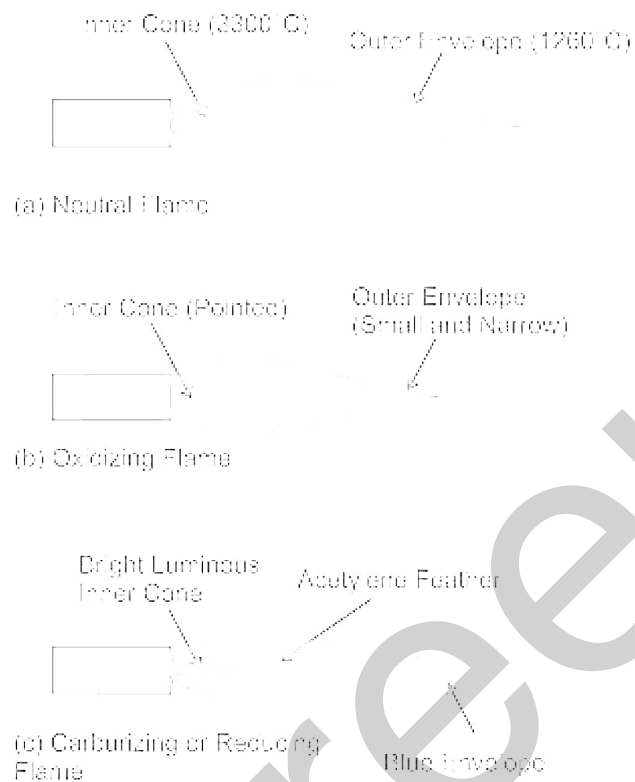

---

28. Answer: c

**Explanation:**

- The 27th Fusion Energy Conference (FEC) was inaugurated in Gandhinagar, Gujarat on 22 October 2018.
- The six-day event is organised by the International Atomic Energy Agency (IAEA) and hosted by the Department of Atomic Energy and Gandhinagar-based Institute of Plasma Research.
- FEC aims to provide a forum for the discussion of key physics and technology issues.

---

29. Answer: a

**Explanation:**

---

**Explanation:**

- Participatory Notes are the instruments issued by registered foreign institutional investors (FII) to overseas investors, who wish to invest in the Indian stock markets.
  - P-Notes or Participatory Notes are Overseas Derivative Instruments that have Indian stocks as their underlying assets.
  - They allow foreign investors to buy stocks listed on Indian exchanges without being registered.
  - This instrument gained popularity as FIIs, to avoid the formalities of registering and to remain anonymous, started betting on stocks through this route.
- 

30. Answer: a

**Explanation:**

**Explanation:**

Apron mechanism

It contains the mechanism for moving and controlling the carriage which is the feature of lathe that provides the method of holding and **moving the tool**.

The main parts of apron are:

- Traversing hand wheel
- Feed lever
- Feed selector
- Lead screw engagement lever

**Important Points**

Headstock

- The headstock is the main body parts that are placed on the left side of the bed.

- 
- The headstock supports the central spindle in the bearings and aligns it correctly.
  - It supports the main spindle in the bearings and aligns it properly.
  - It also houses a necessary transmission mechanism for different speeds.
  - Accessories mounted to the headstock gear mechanism, driving pulley, spindle, etc.

#### Tailstock

- The tailstock fits on the inner ways of the bed and can slide towards any position the headstock to fit the length of the workpiece.
- An optional taper turning attachment would be mounted to it.

The carriage holds the tools and provides movement of the tool in both cross and longitudinal directions.

#### Feed rod

- It is a power transmission mechanism that provides precise longitudinal movement of the carriage.
- For turning the operation movement of the feed, the rod is mandatory.
- In some lathes feed may not be available and lead screw serves the purpose of the feed rod.

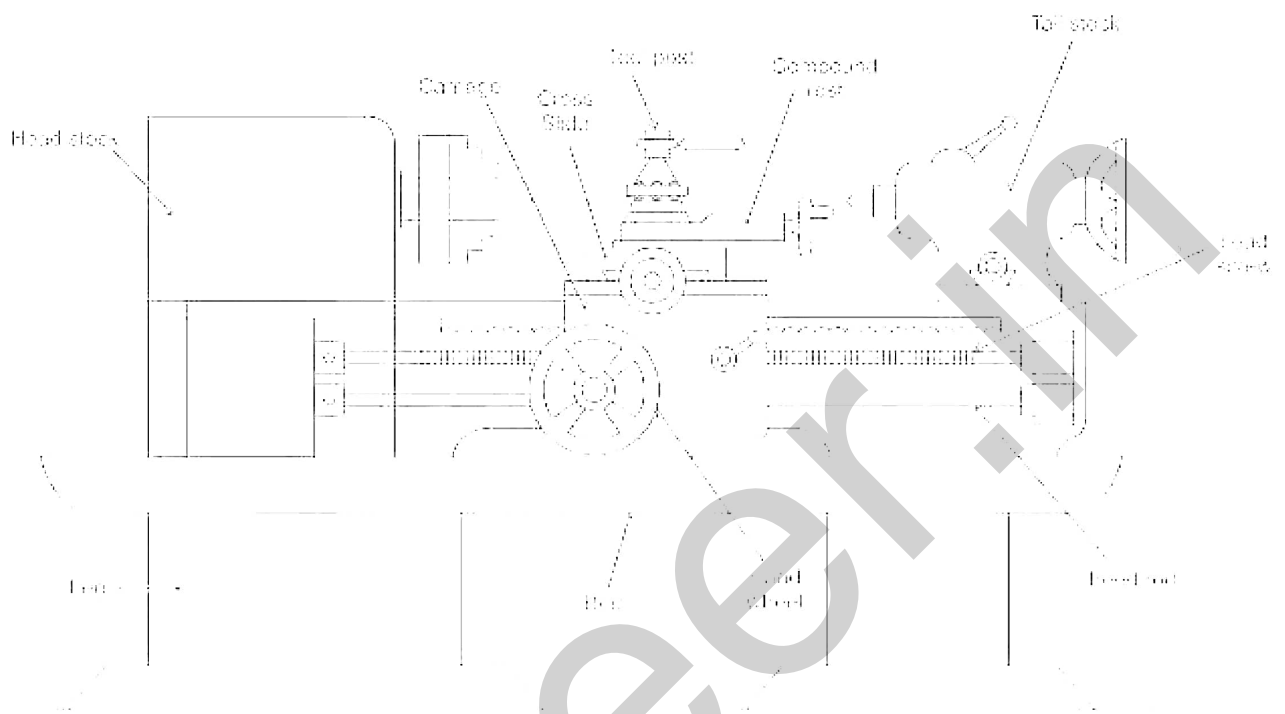

### Mistake Points

- Cross slide in a lathe moves perpendicular to the axis of rotation.
- Apron gives horizontal feed in a lathe machine.

31. Answer: d

**Explanation:**

Explanation:

- Amphoteric oxides are the oxides which can react with both acids and base.
- For example, Aluminium oxide ( $Al_2O_3$ ).
- Aluminium oxide reacts with acids like hydrochloric acid (HCl) and bases like sodium hydroxide (NaOH), to form salt and water.

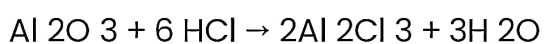

(Salt)

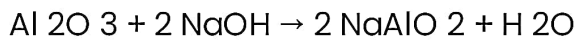

(Salt)

---

32. Answer: d

**Explanation:**

Explanation:

- **Milling** is a process of producing flat and complex shapes with the use of a multi-point (or multi-tooth) cutting tool.
- The axis of rotation of the cutting tool is perpendicular to the direction of feed, either parallel or perpendicular to the machined surface.
- Milling is usually an interrupted cutting operation since the teeth of the milling cutter enter and exit the workpiece during each revolution.
- There are two basic types of milling operations:

Down milling:

- It is also called as **Climb milling**.
- When the cutter rotation is in the same direction as the motion of the workpiece being fed.
- The cutting force is maximum at the beginning and minimum at the end of the cut.
- In down milling, the cutting force is directed on to the work table, which allows thinner parts to be machined without susceptibility to breakage.
- A better surface finish is obtained.

Up milling:

- It is also called as **Conventional milling**.
- In which the workpiece is moving towards the cutter, opposing the cutter direction of rotation.
- The cutting force is minimum during the beginning of the cut and maximum at the end of the cut. In up milling, the cutting action tends to lift the workpiece



---

and hence,

- A proper fixture is required in this operation.

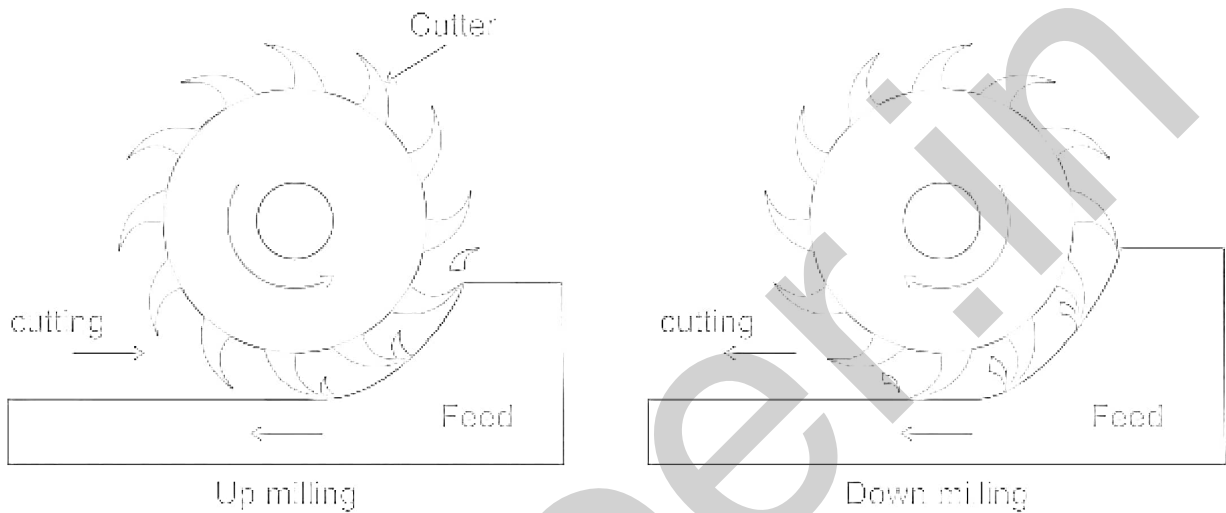

---

33. Answer: c

**Explanation:**

Explanation:

Chambal River:

- It originates from the Singar Chouri peak on the Northern slopes of the Vindhyan Range near Mandav, 67.5 km South-West of Mhow in Indore District of Madhya Pradesh.
- The length of the Chambal river is 1024 km. It enters at Etawah district in Uttar Pradesh and meets the Yamuna river at Muradganj.
- It is a tributary of the Yamuna River in Central India. Thus, it forms part of the greater Gangetic drainage system and forming the boundary between Madhya Pradesh and Rajasthan states before turning South-East to join the Yamuna river in Uttar Pradesh state.
- The Chambal river flows first in a North direction through Madhya Pradesh for about 376 km and then in a generally North-East direction for 249 km

---

through Rajasthan . It flows for another 216 km between Madhya Pradesh and Rajasthan states.

Image view of the Chambal River:

---

**34. Answer: d**

**Explanation:**

The correct answer is Jamnagar.

- Union Minister for Environment and Forests Jairam Ramesh inaugurated the National Centre for Marine Bio-Diversity (NCMB), the first institution in Jamnagar, Gujarat.
- It is the first Public-Private-Partnership (PPP) project with Reliance Industry and also it is the world's largest grassroots level petroleum refinery.

Key Points

- Jamnagar also is known as 'Chhoti Kashi' .
  - Jamnagar is known as 'World's Oil City' .
    - The world's biggest oil refineries, Reliance Industries and Nayara Energy are situated here.
- 

**35. Answer: b**

**Explanation:**

Concept:

**Spirit Level:**

- Spirit level, bubble level, or simply a level is an instrument design to indicate whether a surface is horizontal (level) or vertical (plumb).

---

### Important Points

There are different types of spirit level for different uses:

- Surveyor's leveling instrument
  - Carpenter's level (either wood, aluminum or composite materials)
  - Mason's level
  - Torpedo level
  - Post level
  - Line level
  - Engineer's precision level
  - Electronic level
  - Inclinator
  - Slip or Skid indicator
  - Bull's eye level
- 

36. Answer: b

**Explanation:**

Concept:

The following table shows the different mechanical properties:

---

Creep	<ul style="list-style-type: none"><li>• The tendency of a solid material to move slowly or deform permanently under the influence of mechanical stresses. Creep may also be known as material creep or cold flow.</li><li>• It is basically a time-dependent deformation under a certain applied load.</li><li>• Stresses due to wind loads are varying with time and we know creep is due to sustained loads, therefore no creep deformation is observed due to wind loads.</li><li>• Thermal stresses are also acting over a short time, so no creep deformation is observed due to wind loads also.</li></ul>
Plastic deformation	<ul style="list-style-type: none"><li>• The ability of material is when the applied load is removed and the material does not regain its original/initial shape that deformation is called Plastic deformation</li></ul>
Elastic deformation	<ul style="list-style-type: none"><li>• The ability of material is when the applied load is removed and the material regains its original/initial shape that deformation is called Elastic deformation.</li></ul>
Fatigue	<ul style="list-style-type: none"><li>• It is a failure mechanism that involves the cracking of materials and structural components due to cyclic (or fluctuating) stress. The applied stresses may be tensile, compressive or torsional, crack initiation and propagation are due to the tensile component.</li><li>• One of the intriguing factors about fatigue development is that fatigue cracks can be initiated and propagated at stresses well below the yield strength of the material of construction (these stresses are usually thought to be related to elastic deformation, not plastic deformation).</li></ul>

---

---

37. Answer: d

### Explanation:

#### Explanation:

Properties of a colloid-

- A colloid is a heterogeneous mixture.
- The size of particles of a colloid is too small to be individually seen by naked eyes.
- Colloids are big enough to scatter a beam of light passing through it and make its path visible.
- They do not settle down when left undisturbed, that is, a colloid is quite stable
- They cannot be separated from the mixture by the process of filtration. But, a special technique of separation known as centrifugation, can be used to separate the colloidal particles.

Common Examples of colloids

Dispersed phase	Dispersed medium	Type	Example
Liquid	Gas	Aerosol	Fog, clouds, mist
Solid	Gas	Aerosol	Smoke, automobile exhaust
Gas	Liquid	Foam	Shaving cream
Liquid	Liquid	Emulsion	Milk, face cream
Solid	Liquid	Sol	Milk of magnesia, mud
Gas	Solid	Foam	Foam, rubber, sponge, pumice
Liquid	Solid	Gel	Jelly, cheese, butter
Solid	Solid	Solid Sol	Colored gemstone, milky glass

---

---

38. Answer: b

**Explanation:**

Concept :

The maximum efficiency of screw jack is when helix angle  $\alpha$  is

$$\alpha = 45^\circ - \frac{\phi}{2}$$

**Note:**

If the friction angle is greater than the helix angle, the torque required to lower the load will be positive, indicating that an effort is applied to lower the load. Such a screw is known as a self-locking screw.

Additional Information

Screw jack

- A screw jack is a portable device consisting of a screw mechanism used to raise or lower the load. There are two types of jack Hydraulic and mechanical
- A Hydraulic jack consists of a cylinder and piston mechanism. The movement of piston rod is used to raise or lower the load.
- Mechanical jack can be either hand operated or power driven

The maximum efficiency of screw jack is:

$$\eta = \frac{1 - \sin\phi}{1 + \sin\phi}$$

---

39. Answer: c

**Explanation:**

- 1) The performance of cache memory is frequently measured in terms of a quantity called the Hit ratio.

---

$$\text{Hit ratio} = \frac{\text{hit}}{\text{hit} + \text{miss}}$$

- 2) If the processor finds that the memory location is in the cache, a cache hit has occurred and data is read from the cache.
  - 3) If the processor does not find the memory location in the cache, a cache miss has occurred.
  - 4) Miss ratio = 1 - Hit ratio
- 

40. Answer: b

**Explanation:**

Explanation:

- The addendum is the height by which a tooth of a gear projects beyond (outside for external, or inside for internal) the standard pitch circle or pitch line.
- Also, the radial distance between the pitch diameter and the outside diameter
- In gear drive, Standard Addendum = 1 module

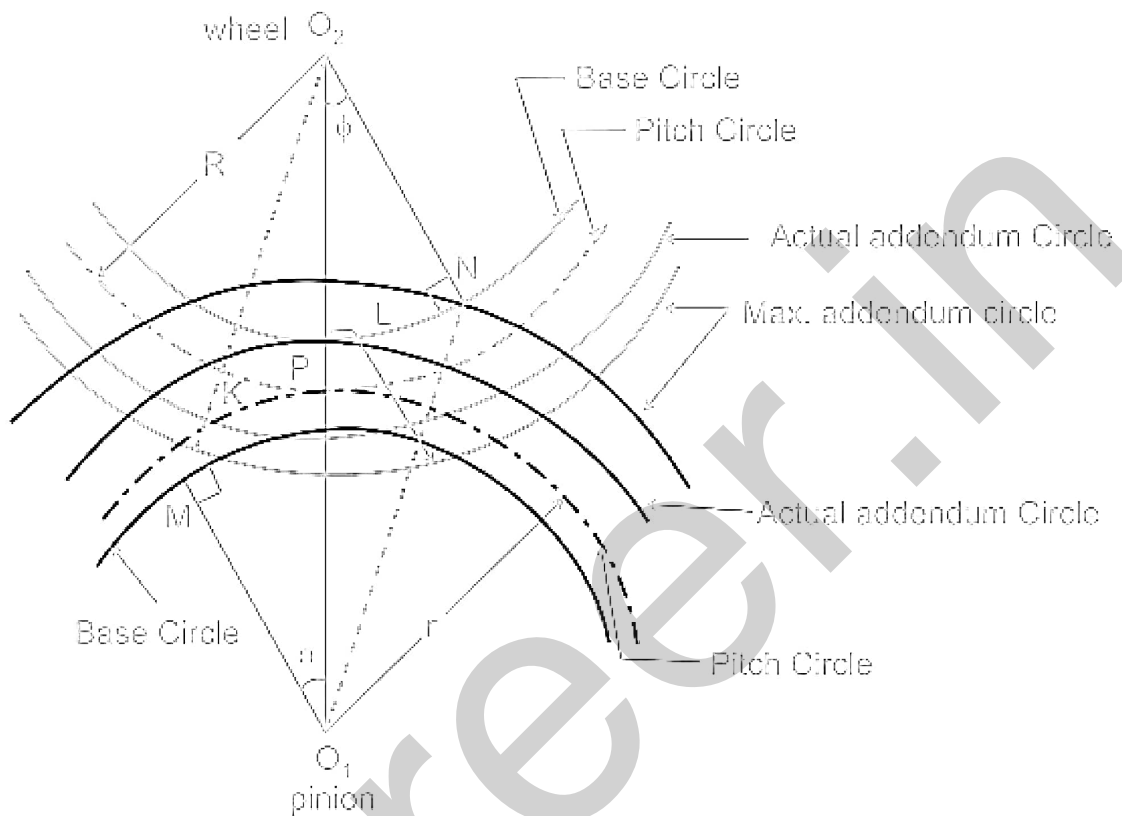

41. Answer: c

**Explanation:**

**Concept:**

The pressure head of water is given as,

$$P = \rho gh$$

where,  $\rho$  = density of water,  $h$  = height of head

**Calculation**

**Given:**

$$\rho = 1000 \text{ kg/m}^3, h = 25 \text{ m}$$

$$\text{Therefore, } P = 1000 \times 9.81 \times 25 = 245.25 \text{ kN/m}^2$$



---

---

42. Answer: d

**Explanation:**

The correct answer is 2,8,2.

- Magnesium (Mg) is a **Group 2 element** in the periodic table.
  - **Atomic number: 12, Atomic mass: 24.31 AMU, Oxidation States: +2.**
  - Magnesium is in the family of **alkaline earth metals**. When purified, magnesium is a very light and silvery metal.
  - It is called a **trace metal**.

Key Points

- Magnesium is used in flashbulbs.
  - When magnesium burns it makes a very bright, white light. Photographers use that white light to help them work in the dark.
- Milk of Magnesia, which works as a laxative and to treat indigestion, is a compound of magnesium, hydrogen, and oxygen molecules.
- Epsom salts, otherwise known as magnesium sulfate.

---

43. Answer: c

**Explanation:**

Concept:

**Beta Distribution:**

- Beta distribution in case PERT is a **3- times estimation** viz. optimistic time ( $t_o$ ), most likely time ( $t_m$ ) and pessimistic time ( $t_p$ ) to calculate the expected duration of the particular activity.

- The normal distribution cannot describe unsymmetrical conditions while **Beta distribution explains both symmetric and un-symmetric patterns.**
- The probability distribution of activity duration may be symmetric or un-symmetric, hence Beta distribution is the best choice for describing the expected duration of an activity.
- **Expected duration of activity ( $t_E$ ) = mean of beta distribution**

### Important Points

#### Poisson's distribution:

- A **Poisson distribution** is a tool that helps to predict the probability of certain events from happening when you know how often the events have occurred .
- **Poisson distribution** is a limiting form of the binomial distribution .
- It is close to zero because it measures a number of defects ( which is already defective ).

#### Ex. Defective fan

Here the reason for defectiveness may be any i.e. it may be a capacitor, coils, etc.

- It gives the probability of a given **number of events happening in a fixed interval of time** .
- In queuing theory, it is used where the **number of arrival per unit time will follow the Poisson distribution.**

#### Normal Distribution:

- According to the central limit, theorem samples may be following any type of distribution but the **universe or population will follow Normal distribution.**
- Similarly, **project activity will follow Beta distribution** but the **project will follow Normal distribution.**
- **Project duration distribution =  $\mu \pm 3\sigma$**

where,  $\mu$  = Critical path duration,  $\sigma$  = Standard deviation of critical path

#### Weibull distribution:

- 
- The Weibull probability distribution can be used as an **alternative model** for task time estimates in the PERT estimating methodology .
  - It has the **same advantage as the traditional Beta distribution** for this application.
- 

#### 44. Answer: a

#### Explanation:

##### Explanation:

##### Truing

- Truing is the operation of changing the shape of the grinding wheel as it becomes worn from an original shape, owing to the breaking away of the abrasive and bond.
- Truing is done to make the periphery of the wheel concentric with its axis and to make its side true and this way to recover the lost shape of its face. Truing is in fact done on glazed wheels.
- Wheel truing is defined as the act of restoring the cutting face of a grinding wheel by removing the abrasive material from the cutting face and sides of the wheel so that it will run true with respect to the axis of rotation and produce perfect round or flat work.
- The wheel truing procedure involves the use of a **diamond – pointed tool** that is fed slowly and precisely across the wheel as it rotates.

##### Dressing

- Dressing of the wheel is done to recover proper cutting action of the wheel face by removing the layer of dulled grains or grains clogged with foreign material. Dressing removes the loading of the wheel.
- Wheel dressing is defined as the act of improving the cutting action. It can also be described as a sharpening operation.

##### Loading

- 
- Grinding wheel is said to be loaded when the metal particles get embedded in the wheel surface blocking the interspaces between cutting grains.
  - Loading is generally caused during the grinding of soft and ductile materials.
  - A loaded, grinding wheel cannot cut properly. Such a grinding wheel can be cleared and sharpened by means of process called dressing.
- 

45. Answer: d

**Explanation:**

Explanation:

**Chilled cast iron:**

- **Chilled iron** is a hematite cast iron abrasive obtained **by atomization**, which is **used for** surface preparation in angular form, mainly in air blast machines.
- A **chilled iron** casting can be **produced by** adjusting the carbon composition of the white cast iron so that the **normal cooling rate at the surface is just enough fast to produce white cast iron** while the **slower cooling rate below the surface will produce gray iron**.
- It could also be used for ballast, counterweight, inoculation, and as an aggregate in high-density concrete.

Important Points

**Other types of Cast iron:**

**Gray cast iron:**

- It is in the form of graphite flakes, so it is also called as flakes cast iron.
- The surface of gray cast iron is very rough.
- Due to the presence of these graphite flakes gray Cast Iron possesses high damping capacity and hence these materials are used for lathe machine beds and engine blocks.
- This possesses more surface roughness and low machinability due to graphite flakes.

---

### Nodular cast iron:

- It is produced by adding magnesium and cerium to the gray cast iron to convert graphite flakes into spherical form.
- Due to the spherical form of graphite in nodular cast iron, the machinability is more.

Ex. **Gears.**

### White cast iron:

- These are produced by the fast cooling of liquid material.
- Due to the fast cooling rate cementite phase is formed instead of graphite, and hence the white cast iron is the hardest and strongest cast iron material.
- These materials are used in the production of rolling mills.

**The annealing process** is a heat treatment process which alters the microstructure of a material to change its mechanical or electrical properties.

Typically, in steels, annealing is used to **reduce hardness, increase ductility, and help eliminate internal stresses.**

---

46. **Answer: d**

### Explanation:

#### Concept:

- **Pascal's principle:** Pascal's Law is the principle of transmission of fluid-pressure.
  - It says that "a pressure exerted anywhere in a point of the confined fluid is transmitted equally in all directions throughout the fluid".
  - **Hydraulic Lift :** The lift that uses pascal's law and used to lift objects with the help of fluid is called hydraulic lift. It works on Pascal's law.

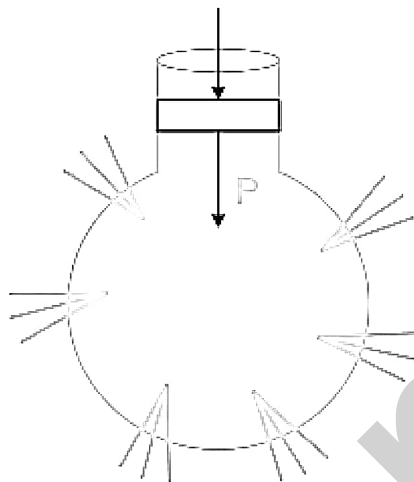

### Important Points

Boyle's, Charles', and Gay Lussac's Laws describe the basic behavior of fluids with respect to volume, pressure, and temperature.

<p><b>Gay Lussac's Law</b></p>	<p>It states that at <b>constant volume</b>, the pressure of a fixed amount of a gas varies directly with temperature.</p> $P \propto T$ $\frac{P}{T} = Const$
<p><b>Boyle's Law</b></p>	<p>For a fixed mass of gas at a <b>constant temperature</b>, the volume is inversely proportional to the pressure.</p> $P \propto \frac{1}{V}$ <p><math>PV = \text{constant}</math> (If the temperature remains constant, the product of pressure and volume of a given mass of a gas is constant.)</p>
<p><b>Charles' Law</b></p>	<p>For a fixed mass of gas at <b>constant pressure</b>, the volume is directly proportional to the Kelvin temperature.</p> $V \propto T \text{ or, } \frac{V}{T} = Const$

---

---

47. Answer: a

Explanation:

Explanation:

- The pressure is measured relative to atmospheric pressure, pressure above atmospheric pressure is **positive gauge pressure** and pressure below atmospheric pressure is **negative gauge pressure** also known as vacuum pressure.
- i.e.  $P_A - P_{atm} \rightarrow$  positive gauge pressure
- $P_{atm} - P_B \rightarrow$  negative gauge pressure
- Absolute pressure is sum of gauge pressure and atmospheric pressure.

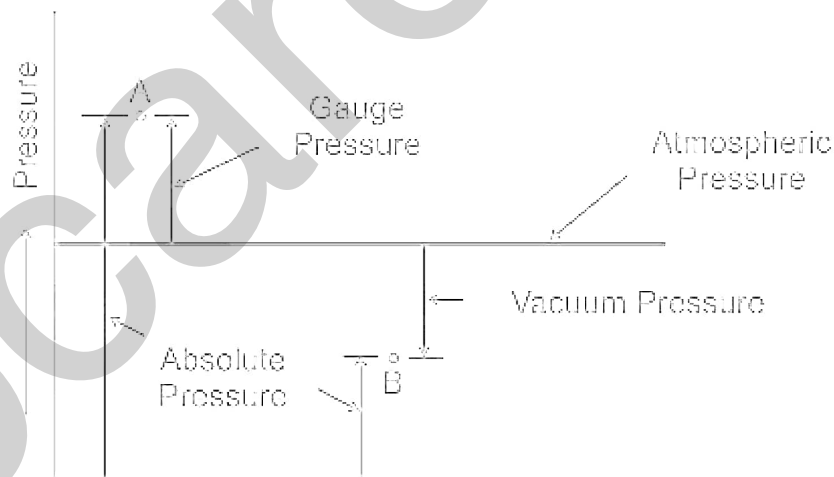

Absolute Zero pressure  
Relationship between pressure.

---

48. Answer: a

Explanation:

Explanation:

---

## Paramagnetic materials

- Small, positive susceptibility to magnetic fields
- These materials are slightly attracted by a magnetic field
- Paramagnetic properties are due to the presence of some unpaired electrons, and from the realignment of the electron paths caused by the external magnetic field
- Paramagnetic materials include magnesium, molybdenum, lithium, and tantalum

### Important Points

## Ferromagnetic materials

- Have a large, positive susceptibility to an external magnetic field
- They exhibit a strong attraction to magnetic fields and can retain their magnetic properties after the external field has been removed
- Ferromagnetic materials have some unpaired electrons, so their atoms have a net magnetic moment
- Iron, nickel, and cobalt are examples of ferromagnetic materials

## Diamagnetic materials

- Weak, negative susceptibility to magnetic fields
- Diamagnetic materials are slightly repelled by a magnetic field
- All the electrons are paired so there is no permanent net magnetic moment per atom
- Most elements in the periodic table, including copper, silver, and gold, are diamagnetic

---

49. Answer: d

**Explanation:**

Explanation:



- 
- Ecology was first coined by the German biologist Ernst Haeckel in 1866, who defined it as "the comprehensive science of the relationship of the organism to the environment."
  - **Ecology is the science treating the reciprocal relations of organisms and the external world.**
  - It is the functional unit of the ecological system which involves complex actions occurring between its biotic and biotic components.
  - The term Ecology system was first used by A.G. Tensley.
  - Dr. Ramdev Mishra is known as the father of ecology in India. He founded the International Society for Tropical Ecology in the year 1956.
- 

50. Answer: b

**Explanation:**

Explanation:

**Clearance angle:**

- The **angle** between a plane containing the end surface of a cutting tool and a plane passing through the cutting edge in the direction of cutting motion.

**Rake angle:**

- **Rake angle** is the **angle** between the **rake** surface and the reference plane as measured on another plane. It indicates the orientation of the **rake** surface of the **cutting** tool.

**Cutting wedge angle:**

- It is the angle between the two intersection lines formed as the corresponding plane of measurement intersects with the rake and flank planes.

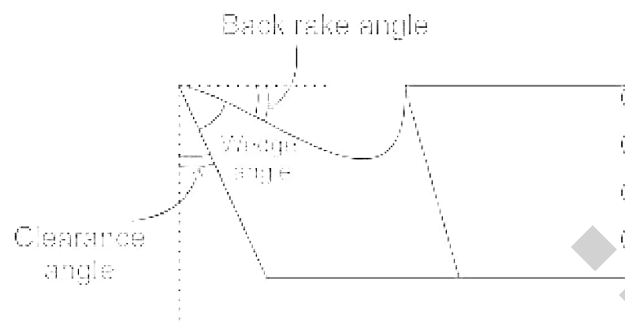

From fig. above

Cutting wedge angle + Rake angle + Clearance angle = 90 degree

Therefore, the sum of cutting edge angle, clearance angle, and rake angle is  $90^\circ$

---

51. Answer: c

**Explanation:**

The correct answer is Football.

Important Points

SPORTS	CUPS and TROPHY
Cricket	Ashes, Reliance Cup, Rothman's Trophy, C.K. Naidu Trophy
Basketball	William's Cup, Bangalore Blues Challenge Cup
Badminton	Thomas Cup, Agarwal Cup, Chadha Cup, Divan Cup
Football	Colombo Cup, Merdeka Cup, Durand Cup
Volleyball	Centennial Cup, Federation Cup, Indira Pradhan Trophy, Shivanthi Gold Cup
Golf	Ryder Cup(men), Solheim Cup(women), Walker Cup
Archery	Archery World Cup
Lawn Tennis	French open cup, US open cup Australian open cup, David open cup(men), Fed Cup(women), Wightman Cup(women)
Table Tennis	Travancore cup (women), Swaythling cup (men) ,

---

	Bama Belleek cup
--	------------------

---

52. Answer: d

**Explanation:**

Explanation:

- The Commonwealth Games take place every four years.
  - **The first Commonwealth Games were held in 1930 in Hamilton, Canada, where 11 countries sent 400 athletes to take part in six sports and 59 events.**
  - The last country to join the Commonwealth was Rwanda (54th country) in 2009.
  - UK, Birmingham is to host the 2022 Commonwealth Games.
- 

53. Answer: b

**Explanation:**

Explanation:

- **Bimbisara belonged to the Haryana dynasty.**
  - Bimbisara (born b.c. 543—died 491 BCE), one of the early kings of the **Indian kingdom of Magadha.**
  - Bimbisara is known as Seniya or Shrenika in the Jain histories.
  - His expansion of the kingdom, especially his annexation of the kingdom of Anga to the east, is considered to have laid the foundations for the later expansion of the Maurya Empire.
  - Bimbisara was the son of Bhattiya.
  - Bimbisara ruled Magadha for a period of 28.
-

---

54. Answer: a

**Explanation:**

Concept:

- **Carburising** is the process of saturating the surface layer of low carbon steels at  $850^{\circ} - 950^{\circ}\text{C}$  with carbon from a carbonaceous source capable of giving up its carbon to the metal.
- There are following methods of carburizing:

**Pack carburizing:**

- In this process, **components are packed in an environment with high carbon content**.
- A **reducing agent (carbon monoxide)** is introduced when heated. Due to high temperatures, carbon monoxide starts to release carbon to be diffuse into the steel surface.
- The materials are then hardened due to carbon absorption. The case depth is approximately 0.1 – 1.5 mm. Pack carburizing **requires high skilled labor**, due to the temperature which is hard to uniform.

**Gas carburizing:**

- **Gas Carburising** is almost similar to Pack Carburising except for the part where the supply of carbon monoxide gas to the heated furnace and carbon decomposition.
- The carbon monoxide gases are contained safely and the components are enclosed in **a carbon filed enclosure that is replenished continuously to maintain high carbon content which results in a high production rate in comparison to pack carburizing.**
- A lot of problems that are faced in Pack Carburising are solved by using this process.
- This method can be **used in mass production.**

Important Points

**Liquid Carburising:**

- 
- For this process, the steel components are immersed in a liquefied carbon-rich environment (cyanide). Another method is by using molten salt.
  - The molten salt can also introduce carbon into the metal. The metal is then undergone rapid quenching. The **quality produced is similar to the ones in Gas Carburising**, but with **low nitrogen and high carbon content**.

#### Solid powder carburizing:

- In this method, the **carburizing** compound is a **solid carburized**, usually charcoal of 3 to 10 mm size (fines are screened off), or coke, semi-coke, or coal.
- To accelerate the **carburizing** activator, or energizer normally  $\text{BaCO}_3$  and/or  $\text{Na}_2\text{CO}_3$  in amounts 10–30% of charcoal is added.

---

55. Answer: b

#### Explanation:

##### Concept:

##### Contour turning:

- In this operation of the **lathe machine**, the tool is not feed in a straight path.
- Instead, the tool follows a **contour**, a contoured form is created in the **turned** part.

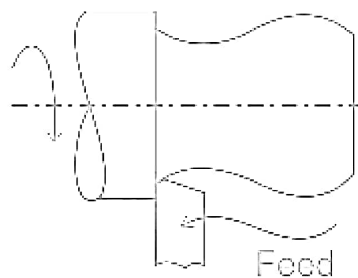

Contour turning

#### Important Points

##### Taper turning:

- The turning operation **used for producing the taper on the cylindrical component** is called a taper turning operation.

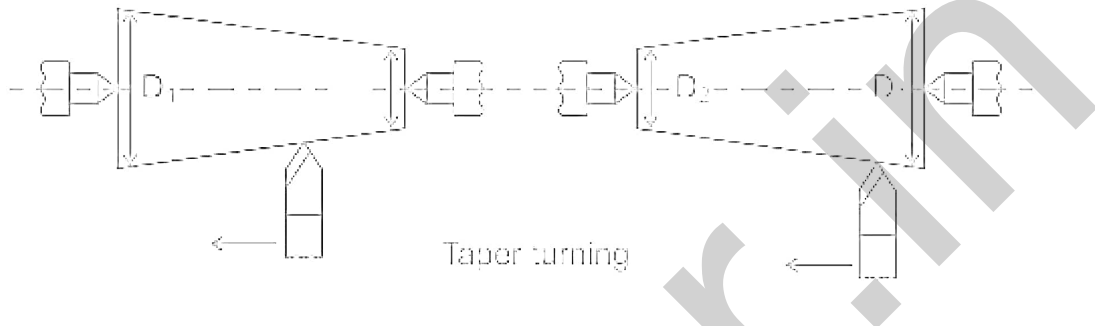

### Facing:

- The turning operation **used for reducing the length** of the component is called the face turning operation.
- **Facing** is mostly used to finish the edges in necklines, armholes, hems, and openings. They are also used widely in all other sewings like quilts and home decor items like curtain hems.
- Shaped facings are cut to match the outside shape of the piece to provide a neat finish, and are often cut from the same pattern pieces.

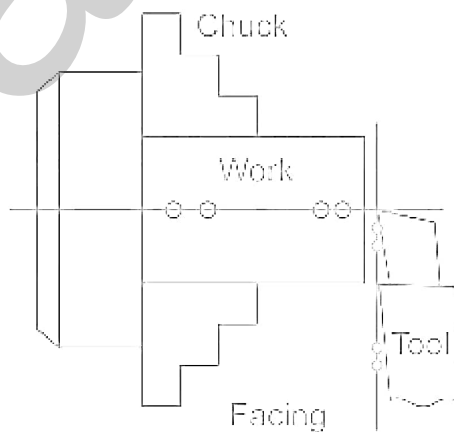

### Form Turning:

- It is a method of taper turning in which a broad nose tool having a straight cutting edge is set on to the work at half taper angle and is feed straight into the work to generate a tapered surface.
- With this method, tapers of only short lengths can be turned.

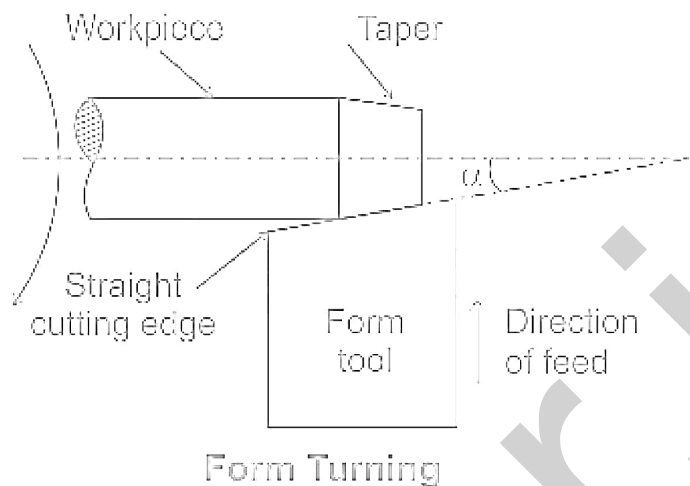

56. Answer: c

**Explanation:**

The correct answer is Mortality rate.

- A mortality rate is the number of deaths during a particular period of time among a particular type or group of people.
  - It is also called the **Death Rate**, that measured as **the number of deaths per thousand persons in a year**.

#### Important Points

- The emigration rate is the number of emigrants departing an area of origin per 1000 population in that area of origin in a given year.
  - The emigration rate depends on the number leaving in a given period and the population at risk of leaving, weighted by the duration at risk.
- The natality rate is defined as a birth rate in a particular population.
  - It means the total number of live births per 1000 population during a given time period or a year.
  - Natality rate = The number of births dividing by the sum of the time at risk of giving birth over all individuals.
- Immigration Rate is the number of immigrants arriving at a destination per 1,000 population at that destination in a given year.



- 
- According to the United Nations, the United States has the highest number of immigrants (foreign-born individuals), in 2019

### Key Points

- The crude death rate is defined as the mortality rate from all causes of death for a population.
    - Crude death = total number of deaths during a given time interval divided by the mid-interval population.
- 

57. Answer: d

### **Explanation:**

The correct answer is Vibrio cholerae.

### Explanation:

A Communicable Disease is an infectious disease that is transmissible by contact with infected individuals or their bodily discharges or fluids (as respiratory droplets, blood, or semen), by contact with contaminated surfaces or objects, by ingestion of contaminated food or water, or by direct or indirect contact with disease vectors (as mosquitoes, fleas, or mice).

- Cholera is a communicable disease characterized by intense vomiting and profuse watery diarrhea and that rapidly leads to dehydration and often death.
- Cholera is caused by infection with the bacterium *Vibrio Cholera*, which may be transmitted via infected fecal matter, food, or water.
- Cholera is an acute, diarrheal illness caused by infection of the intestine with the toxigenic bacterium. The infection is often mild or without symptoms, but can sometimes be severe.

### NOTE:

- *Mycobacterium Leprae* is a bacterium that causes leprosy, also known as 'Hansen's disease', which is a chronic infectious disease that damages the

- 
- peripheral nerves and targets the skin, eyes, nose, and muscles.
- Leprosy can occur at all ages from infancy to elderly but is curable in which treatments can avert disabilities.
  - Tuberculosis (TB) is caused by a bacterium called Mycobacterium Tuberculosis . The bacteria usually attack the lungs, but TB bacteria can attack any part of the body such as the kidney, spine, and brain. Not everyone infected with TB bacteria becomes sick. As a result, two TB-related conditions exist latent TB infection (LTBI) and TB disease.
  - Tetanus an infection caused by bacteria called Clostridium Tetani . When the bacteria invade the body, they produce a poison (toxin) that causes painful muscle contractions. Another name for tetanus is "lockjaw".

Therefore, from the above points, it can be inferred that the communicable disease Cholera is caused by the bacteria Vibrio Cholera.

---

58. Answer: c

**Explanation:**

Concept:

Product Layout:

- It is also known as **line layout**.
- It implies that various operations on raw material are performed in a sequence and the machines are placed along the product flow line i.e. machines are arranged in the sequence in which the raw material will be operated upon.
- This type of layout is preferred for continuous production i.e. involving a continuous flow of in-process material towards the finished product stage.

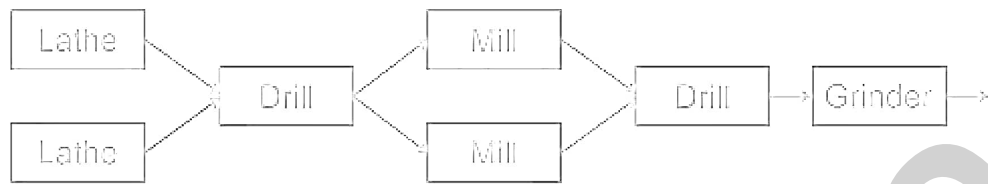

A Simple product layout

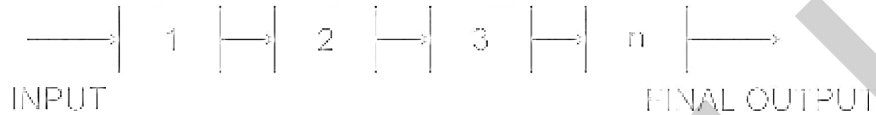

#### Advantages:

- Smooth and logical flow lines
- Small in-process inventories
- Short total production time/unit
- Reduced material handling
- Little operator skill, simple training
- Simple production planning & control
- Less space for work in transit and temporary

#### Process Layout:

- It is also known as a **functional layout** and is characterized by keeping similar machines or similar operations at one location (place).
- In other words, all lathes will be in one place, all milling machines at another, and so on, that is machines have been arranged according to their functions.

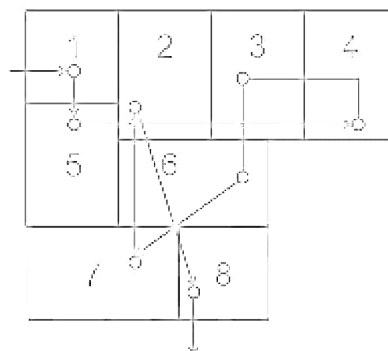

Process Layout showing product movements

1. Store room.
2. Inspection Department.
3. Broaching Section.
4. Milling Section
5. Lathe Section.
6. Shaper Section.
7. Drill Section.
8. Stock room

---

59. Answer: b

### Explanation:

#### Concept:

#### Reversible process:

A process is said to be reversible if its system as well as surrounding **regains its initial state**.

#### Electrolysis:

- **Electrolysis** is the **process** by which ionic substances are decomposed (broken down) into simpler substances when an electric current is passed through them.
- Electricity is the flow of electrons or ions. For **electrolysis** to work, the compound must contain ions.
- Under conditions of electrolysis, the cell is operating away from its equilibrium (reversible) potentials determined from thermodynamics.
- Certain electrode reactions are very fast and depart very little from the equilibrium potential. Such reactions are frequently referred to as **reversible**.
- **Reverse electrolysis** can be used to put rust on ferrous metal.

#### Additional Information

#### Heat transfer:

- For a system that exchanges heat with its surroundings, ***a process can be reversible only if the temperatures of the system and the surroundings are arbitrarily close to one another.***
- A system can undergo a reversible change adiabatically.

#### Combustion:

- **Combustion** is a chemical **process** in which a substance reacts rapidly with oxygen and gives off heat and it is a highly irreversible process as one cannot produce combustible products again.

---

**Plastic deformation:**

- **Plastic deformation** is the permanent distortion that occurs when a material is subjected to tensile, compressive, bending, or torsion stresses that exceed its yield strength and cause it to elongate, compress, buckle, bend, or twist.
  - Therefore it is said to be an irreversible process as it is impossible to regain to original shape of raw material from permanent plastic deformation.
- 

**60. Answer: b**

**Explanation:**

Explanation:

- Stockholm Convention :
    - **It was signed in the year 2001 and came into effect from 2004.**
    - It is a multilateral environmental agreement to protect human health and the environment from persistent organic pollutants (POPs) .
  - Basel Convention :
    - It is an international treaty signed in 1989 and came into effect from 1992.
    - it was designed to protect human health and the environment against the adverse effects of hazardous wastes .
    - it regulated the movements of hazardous waste between nations, and specifically to prevent the transfer of hazardous waste from developed to less developed countries.
  - Rotterdam Convention :
    - It was signed in the year 1998 and came into effect from 2004.
    - It is a multilateral environmental agreement to promote shared responsibilities in relation to the importation of hazardous chemicals.
- 

**61. Answer: d**

**Explanation:**

---

**Path** is a free of cost repair of software bug available at Internet.

**Key Points**

- A patch is a set of changes to a computer program or its supporting data designed to update, fix, or improve it.
  - This includes fixing security vulnerabilities and other bugs, with such patches usually being called bug fixes.
  - Patches are often written to improve the functionality, usability, or performance of a program.
- 

62. Answer: a

**Explanation:**

**Explanation :**

- The screw is considered as an inclined plane with inclination  $\alpha$ .
- When a load is being raised, the following force acts on it at a point on the inclined plane.
- **Load (W)** : It always acts in a vertically downward direction, **Normal Reaction (N)** : It acts perpendicular to the inclined plane.
- **Frictional force ( $\mu N$ )** : Frictional force acts opposite to the motion. Since the load is moving up the inclined plane, the frictional force acts along the inclined plane in the downward direction.
- **Effort (P)** : Effort P acts perpendicular to the load W. It acts towards right for lifting the load and towards left for lowering the load.

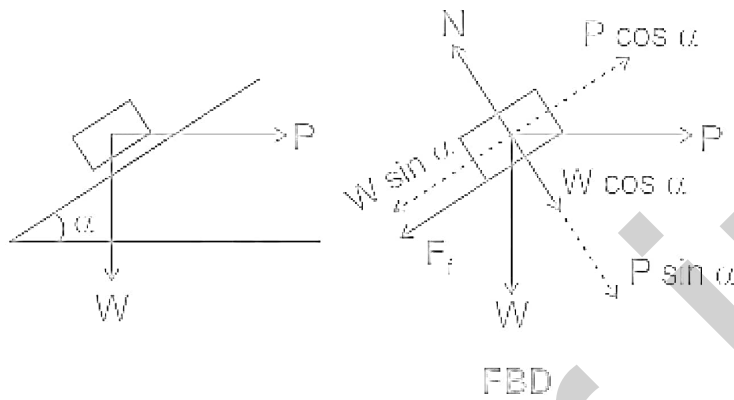

From FBD of the figure.

$$\Sigma F_x = 0$$

$$P \times \sin \alpha + W \times \cos \alpha = N.$$

$$\Sigma F_y = 0$$

$$W \times \sin \alpha + \mu N = P \times \cos \alpha$$

$$W \times \sin \alpha + \mu(P \times \sin \alpha + W \times \cos \alpha) = P \times \cos \alpha$$

$$W \times \sin \alpha + \mu W \times \cos \alpha = P \times \cos \alpha - \mu P \times \sin \alpha$$

$$\therefore P = \frac{W(\sin \alpha + \mu \cos \alpha)}{\cos \alpha - \mu \sin \alpha}$$

$$\Rightarrow P = W \left( \frac{\tan \alpha + \mu}{1 - \mu \tan \alpha} \right)$$

$$\Rightarrow P = W \left( \frac{\tan \alpha + \tan \phi}{1 - \tan \alpha \tan \phi} \right) \quad [ \because \mu = \tan \phi ]$$

$$\therefore P = W \times \tan (\alpha + \phi) .$$

63. Answer: b

Explanation:

Explanation:

- SI Unit of Electric Potential difference is **Volt (V)**.
- The Electric Potential difference is also known as Voltage.
- Voltage is measured using Voltmeter.
- Electric Potential difference (V) = Work done/Charge

$$V = \text{Joule/Coulomb}$$

Units	Physical Unit
Watts	Power
Ohms	Resistance
Coulomb	Charge

64. Answer: a

**Explanation:**

The correct answer is C<sub>2</sub>H<sub>2</sub>.

- Acetylene or ethyne is a hydrocarbon and the simplest alkyne chemical compound with the formula C<sub>2</sub>H<sub>2</sub>.
- Acetylene is also called Narcylen or Vinylene
- It has two carbon atoms are bonded together in a triple bond.
- Shape: Linear, Hybridization Type: sp.

Important Points

CH <sub>3</sub>	Methyl
C <sub>3</sub> H <sub>2</sub>	Propynylidene
CH <sub>2</sub>	Methylene

Key Points



- 
- Acetylene is used in **welding and cutting processes**.
    - The welding process using acetylene is known as **cutting oxy-fuel or cutting coal**.
- 

65. Answer: b

**Explanation:**

The correct answer is Orange.

Explanation:

- The fruits containing citric acid are termed as citrus fruits. eg: lemon, orange, grapefruit, etc.
- These are sour in taste and are a good source of Vitamin C, thus help in preventing the disease caused by the deficiency of Vitamin C, i.e., Scurvy.
- Grapes contain a lesser amount of citric acid than lime.
- Banana is a rich source of fiber, potassium, and Vitamin B6.
- Mango is a food source of fiber and Vitamin A and C.

Few naturally occurring acids are -

<u>Sl no.</u>	<u>Name of the Acid</u>	<u>Generally Found in</u>
1	Tartaric acid	Grapes, tamarind
2	Lactic acid	Curd
3	Formic acid	The sting of bees and red ants
4	Gastric Juice/ HCL	Human stomach
5	Oxalic acid	Tomatoes
6	Citric acid or Ascorbic Acid	Orange or lemon, gooseberries (amla)
7	Acetic Acid	Vinegar

---

---

66. Answer: d

**Explanation:**

Concept:

Reynolds Number:

- It is the ratio of the inertial forces to viscous forces.
- It is a dimensionless number used to categorize the fluid systems in the effect of viscosity is important in controlling the velocities or the flow pattern of a fluid.
- Reynolds Number = (inertial forces) / (viscous forces)

Mathematically, Reynolds Number is

$$Re = \frac{\rho V d}{\mu}$$

Where,  $\rho$  = density,  $V$  = velocity,  $d$  = diameter,  $\mu$  = viscosity

Reynolds number is important for decreasing the transport properties of a fluid or a particle moving in a fluid.

Flow-through pipes are classified into three main categories:

1. **Laminar flow: Reynolds no. < 2000**
2. Critical flow:  $2000 < \text{Reynolds no.} < 4000$
3. Turbulent flow: Reynolds no.  $> 4000$

Note:

- Reynolds no. less than 2000 (Laminar flow) is also known as viscous flow.
- With a strong predominance of inertial forces over viscous forces, the largest scales of fluid motion are underdamped i.e. there is not enough viscosity to dissipate their motions.

---

67. Answer: b

---

## Explanation:

### Explanation:

#### Marquenching or Stepped Quenching

- Articles are first **quenched** in water to a temperature of **300-400°C** and then quickly transferred to a less intensive medium like oil or air where they are held until they are completely cooled.
- This method is widely used in the **heat treatment** of **steel tools** like **taps, disc, milling cutter**, etc.
- A larger holding time will cause austenite decomposition. **Austenite** is transformed into **martensite** during the subsequent period of cooling to the room temperature.

#### Important Points

Heat Treatment Processes	Advantages
Austempering	<ul style="list-style-type: none"> <li>• <b>Quenching</b> cracks between core and surface do not develop.</li> <li>• <b>Ductility</b> is increased.</li> <li>• <b>Impact strength</b> and <b>toughness</b> are increased.</li> </ul>
Annealing	<ul style="list-style-type: none"> <li>• To reduce <b>hardness</b></li> <li>• To improve <b>machinability</b></li> <li>• To refine grain size</li> <li>• To relieve <b>internal stresses</b></li> </ul>
Tempering	<ul style="list-style-type: none"> <li>• <b>Residual stresses</b> are relieved</li> <li>• Ductility is improved</li> <li>• Toughness is increased</li> </ul>

68. Answer: c

**Explanation:**

Explanation:

Tungsten Inert Gas (TIG) or Gas Tungsten Arc (GTA) welding is the arc welding process in which arc is generated between **non-consumable tungsten electrode and workpiece**.

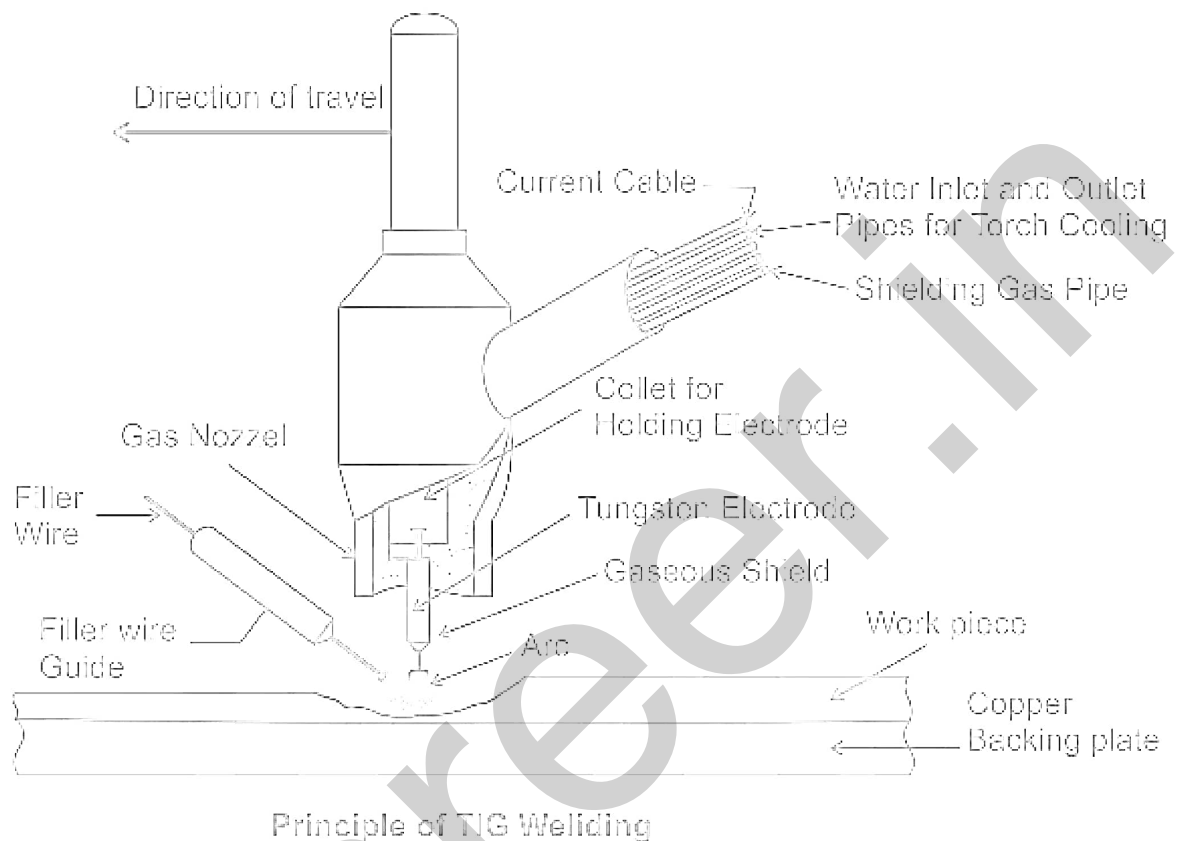

- Gas metal arc welding (GMAW) or Metal inert gas arc welding (MIG): In this process, the arc is formed between a continuous, automatically fed, metallic consumable electrode and welding job in an atmosphere of inert gas, and hence this is called metal inert gas arc welding (MIG) process.
- Submerged arc welding: Here the arc is formed between a continuous, automatically fed, metallic consumable electrode and the welding job under a heap of powdered/granulated flux. The arc is totally submerged in the flux (invisible).
- Manual metal arc welding (MMAW) or shielded metal arc welding (SMAW) is the oldest and most widely used process being used for fabrication. This is an arc welding process in which the welding heat is obtained from an arc, formed between a metallic (consumable) electrode and welding job.

69. Answer: b

---

## Explanation:

The correct answer is McAfee.

- McAfee is a Computer security software or Anti-virus.

### Key Points

- McAfee is a Virus Removal Service software that detects and eliminates viruses like **Trojans, spyware, and other malware from the computer.**
- It also identifies any malicious applications or malware and removes them from the computer.
- The CEO of this company is Peter A. Leav.

### Additional Information

Polymorphic	<ul style="list-style-type: none"> <li>• It is a type of malware that constantly changes its identifiable features to evade detection.</li> <li>• It changes file names and types of encryption keys to make the malware unrecognizable to many detection techniques.</li> <li>• It includes viruses, worms, bots, trojans, or keyloggers.</li> <li>• Examples of polymorphic malware are Storm Worm Email, CryptoWall Ransomware.</li> </ul>
Multipartite	<ul style="list-style-type: none"> <li>• This virus can attack both the boot sector and executable files of an infected computer.</li> <li>• When the virus attaches to the boot sector, it will in turn affect the system files.</li> <li>• When the virus attaches to the files, it will, in turn, infect the boot sector.</li> </ul>
Boot sector	<ul style="list-style-type: none"> <li>• It infects the boot sector of floppy disks or the Master Boot Record (MBR) of hard disks.</li> <li>• Bad effect on the partition table of a Hard disk where startup files are found.</li> </ul>

### Important Points

- There are many anti-virus software like Norton, Avira, Avast, Kaspersky, Bitdefender, AVG, etc.

70. Answer: d

**Explanation:**

Explanation:

---

## Hardness

- It is the measure of materials localized plastic deformation.
- Hardness test are performed by forcing a small indenter into the surface of a material to be tested and under controlled conditions of load and rate of application.
- The size of the resulting indentation is related to hardness numbers.

### Rockwell hardness test:

- Rockwell hardness testers use a number of indenters in combination with a variety of loads.
- It has 1/16, 1/8, 1/4, 1/2 inch diameter spherical steel indenter as well as conical diamond indenter which is used for the hardest material.
- Each of the indenters can be used with a major load of 60, 100, or 150 kg, and a minor load of 10 kg.
- The hardness number is the **difference between the penetrations** caused by major and minor load applications.
- Based on these load and indenters scales are developed,
  - Rockwell A scale , 60 kg with diamond indenter is used for steels and similar hard alloys .
  - Rockwell B scale , 100 kg with 1/16 inch diameter sphere indenter are used for aluminum alloys.
  - Rockwell C scale , 150 kg with the diamond pyramid indenter are used for steel and similar hard alloys .
  - Copper alloys are measured in k scales.
  - Polymers are measured in the Rockwell E and M scales. M scales are used for hard polymers.

### Brinell hardness Scale:

- In Brinell hardness test a hard spherical indenter of 10 mm diameter is used, and the load varies between 500 and 3000 kg.
  - Harder materials require greater applied load.
-



---

71. Answer: d

**Explanation:**

Explanation:

- Gunmetal is typically composed of 86% copper, 9.5% tin, 2.5% lead, and 2% zinc .
- It was used mainly for making guns and bullets . Now it is superseded by Steel.
- Gunmetal is used extensively for making heavy machinery parts as it can withstand high pressure and is corrosion resistant.

---

72. Answer: c

**Explanation:**

Explanation:

A schematic diagram of vapour compression refrigeration cycle is shown below

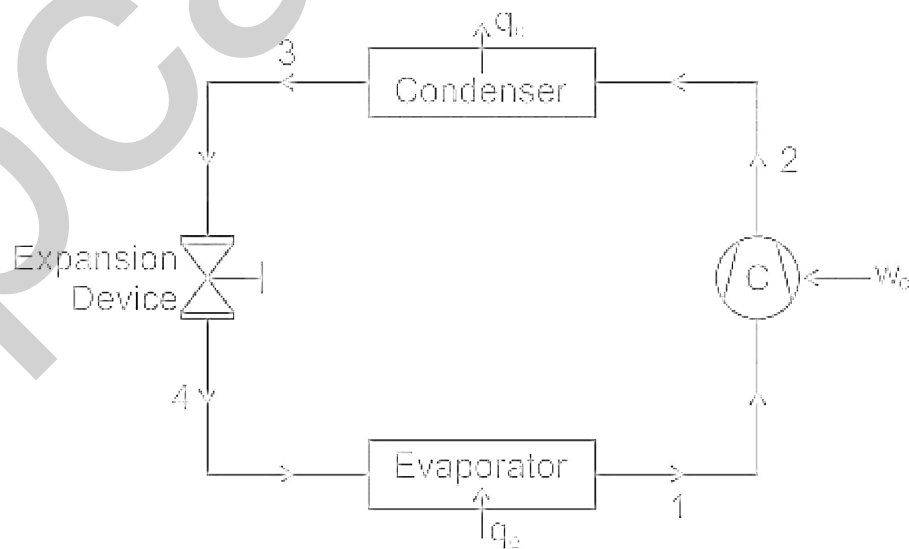

Following are the process and changes in refrigerant when they pass through the different equipment of the refrigeration cycle

- 
- Compressor-Process 1-2 : The refrigerant is compressed isentropically from stage 1 to stage 2.
  - Condenser-Process 2-3: In the condenser, the heat is rejected by the refrigerant at constant pressure
  - Expansion Device-Process 3-4 : The refrigerant is expanded in an irreversible adiabatic manner from stage 3 to stage 4.
  - Evaporator-Process 4-1 : In the evaporator , heat is absorbed by the refrigerant at constant pressure.
- 

73. Answer: c

**Explanation:**

Explanation:

The full form of CMM is **Coordinate Measuring Machine** .

**Coordinate Measuring Machine**

- It is one of the most powerful **metrological instruments** ; coordinate measuring machines are widely used in most **manufacturing plants**, large and small.
  - **CMMs** are referred to as those machines that give physical representations of a three-dimensional rectilinear Cartesian coordinate system.
  - The basic **hardware elements** of a typical CMM include **structural elements** ,**supporting bearings, drive systems, feedback elements, probe head, and control systems** .
- 

74. Answer: c

**Explanation:**

Explanation:

- 
- Soldering is the process by which metallic materials are joined with the help of another liquified metal (solder)
  - Soldering can be classed as soft soldering and hard soldering.
  - The process of joining metals using tin-lead solders which melt below  $420^{\circ}\text{C}$  is known as soft soldering
  - The process of joining metals using hard solders consisting of copper, zinc, cadmium and silver which melt above  $600^{\circ}$  is known as hard soldering
  - The eutectic alloy of tin-lead solder is a mixture of 63% tin and 37% lead. 63/37 solder melts at  $183^{\circ}\text{C}$
- 

**75. Answer: b**

**Explanation:**

Explanation:

Coefficient of discharge is the ratio of actual discharge to the theoretical discharge.

Coefficient of discharge

⇒ Venturimeter – 0.95 to 0.98

⇒ Orifice meter – 0.62 to 0.65

⇒ Nozzle meter – 0.93 to 0.98

**Important Points**

The coefficient of discharge for the venturimeter lies is higher than the nozzle meter and orifice meter.

---

**76. Answer: b**

**Explanation:**

---

**Explanation:**

If  $\epsilon$  represents the energy of one molecule, then

$$\epsilon = \epsilon_{\text{trans}} + \epsilon_{\text{rot}} + \epsilon_{\text{vib}} + \epsilon_{\text{chem}} + \epsilon_{\text{nuclear}}$$

If  $N$  is the number of molecules in the system, then the total internal energy is

$$U = N\epsilon$$

For an **ideal gas or perfect gas**, there are no intermolecular forces of attraction and repulsion, and the internal energy depends only on temperature. Thus, for an ideal gas  $U = f(T)$  only.

---

**77. Answer: a**

**Explanation:**

The Correct Answer is Option 1 i.e. Himadri.

- **Himadri:**
  - It is India's **first permanent Arctic research station** .
  - It is located at Spitsbergen Island, Norway.
  - It serves as a hub of Indian scientific investigations since 2008.
- **Dakshin Gangotri:**
  - It is **India's first Antarctic research** facility.
  - It was established in 1984 in Antarctica as part of the Indian Antarctic Programme.
  - It is now being used as a supply base.
- **Maitri:**
  - It is **India's second permanent research station** in **Antarctica** .
  - It is situated on the rocky mountainous region called Schirmacher Oasis.
  - It was established in the year 1988.
- **Bharati:**
  - The Bharati station is operational since March 2012.
  - It is located in Larsemann Hills, **Antarctica** .

- 
- It is India's **third Antarctic research** facility.
- 

78. Answer: d

**Explanation:**

**Concept:**

As per Newton's third law of motion,

- **Action and reaction act on different bodies**
- The magnitude of the force exerted by the bodies is equal
- **Action and reaction act in the opposite direction**
- Both action and reaction are simultaneous in nature, which means there will be a reaction until the action is taking place

The figure below shown is an example of Newton's third law of motion-

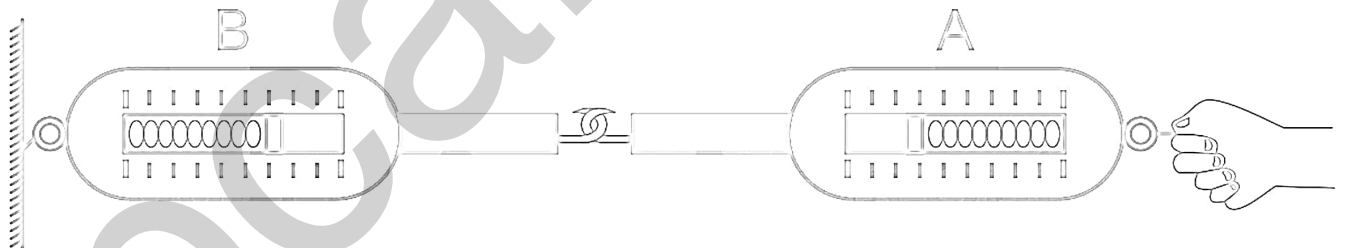

Action and reaction forces are equal and opposite

---

79. Answer: c

**Explanation:**

- David Warner won the Orange Cap in the 2019 VIVO IPL.
- Mumbai Indians won the 2019 IPL championship for the fourth time after defeating Chennai Super Kings by one run in a thrilling final in Hyderabad.

---

Awards	Won by
Orange cap	David Warner
Purple cap	Imran Tahir
Highest Individual Score	Jonny Bairstow

---

80. Answer: a

**Explanation:**

Explanation:

- The Jallianwala Bagh massacre is also known as the Amritsar massacre.
  - It happened on April 13, 1919, when Acting Brigadier-General Reginald Dyer ordered British Indian Army troops to fire their rifles at a crowd of unarmed Indian civilians in Jallianwala Bagh, Amritsar, Punjab.
  - The Asian Awards honored the Jallianwala Bagh Martyrs with the prestigious Founders Award in April 2019.
  - Colonel Reginald Edward Harry Dyer was a Bengal Army general.
  - His military career started to serve briefly in the regular British Army before being transferred to serve with India's presidential armies.
  - He was responsible as a temporary brigadier-general for the Amritsar massacre at Jallianwala Bagh.
- 

81. Answer: d

---

## Explanation:

### Concept:

Optimum number of quantities ( $Q^*$ ) can be calculated by:

$$Q^* = \sqrt{\frac{2DC_0}{C_h}}$$

where,  $D$  = Demand rate for a particular item,  $C_0$  = Ordering cost per order,  $C_h$  = Holding cost per item per year

$$\text{Number of orders per year } (N) = \frac{D}{Q^*}$$

### Calculation:

#### Given:

$D = 12000$  units/year,  $C_0 = \text{Rs.}100/\text{order}$   $C_c = 0.80$  per item per month =  $0.80 \times 12 = 9.6$  Rs. per item per year

No shortages are allowed and replacement is instantaneous

$$Q^* = \sqrt{\frac{2DC_0}{C_c}} = \sqrt{\frac{2 \times 12000 \times 100}{9.6}} = 500 \text{ units}$$

$$\text{The number of orders per year } (N) = \frac{D}{Q^*} = \frac{12000}{500} = 24 \text{ orders}$$

---

## 82. Answer: d

### Explanation:

#### Explanation:

Materials requirements planning is a simple system of calculating arithmetically the requirements of the input materials at different points of time based on actual production plan.

---

It can be seen from the figure that an MRP system has three major input components:

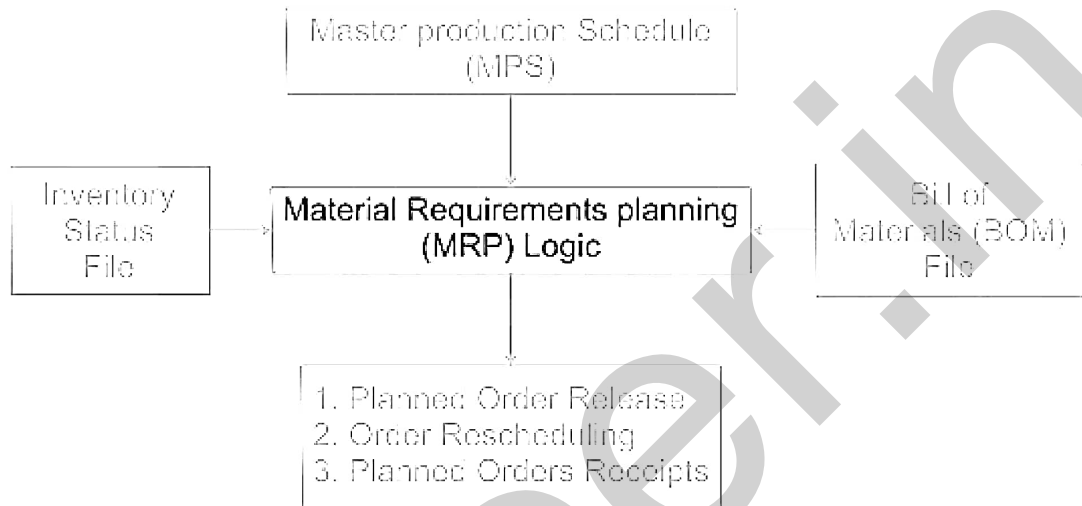

**Master Production Schedule (MPS):** MPS is designed to meet the market demand (both the firm orders and forecasted demand) in future in the taken planning horizon. MPS mainly depicts the detailed delivery schedule of the end products. However, orders for replacement components can also be included in it to make it more comprehensive.

**Bill of Materials (BOM) File:** BOM represents the product structure. It encompasses information about all subcomponents needed, their quantity, and their sequence of build-up in the end product. Information about the work centres performing build-up operations is also included in it.



---

### Bill of Material

Customer name: ABC Company  
Customer address: 123 Jane Avenue, New York  
Date: 1/1/2010

---

Item #	Description	Vendor	Part Number	Quantity
1	FGHT sun model	MNF	GHY255	7
2	120 w photovoltaic module	Food FG	2543 L	14
3	Hardware	Mottle	1-152-UKL	2
4	4-module for GHX	IFS	2565N	1
5	822 air G	Mood pic	847873 IOI	4
6	SMA Model Sunny Boy Inverter	MNF	2 GH	2
7	8B, 700 GHT	IFS	153	1
8	Fused Disconnect Switch	Food FG	56e	1

---

**Inventory Status File:** Inventory status file keeps an up-to-date record of each item in the inventory. Information such as, item identification number, quantity on hand, safety stock level, quantity already allocated, and the procurement lead time of each item is recorded in this file.

---

**83. Answer: b**

#### **Explanation:**

##### Explanation:

Case hardening is a method used to harden the outer surface of low-carbon steel while leaving the centre or core soft and ductile. Case hardening involves heating the metal to its critical temperature in some carbonaceous material. The following methods are commonly used:

1. Pack method
2. Cyaniding

---

3. Nitriding

4. Induction Hardening

5. Flame hardening

Cyaniding:

- In this process of surface hardening, both carbon and nitrogen are added to the surface layer of steel (ferrous material, usually low carbon grade).
  - The process is based on the decomposition of cyanide compounds that easily release the cyan group (CN).
  - Cyaniding involves heating the steel in a liquid or solid medium.
  - **The steel is heated in a molten cyanide salt bath maintained at 950°C, followed by water or oil quenching.**
  - Salt bath compositions may vary according to the temperature of the salt, the thickness of the case to be obtained, type of steel to be heat treated and period of operation.
  - Case thickness from 0.075 – 1.5 mm can be obtained in the process.
- 

84. Answer: c

Explanation:

Explanation :

Electrochemical Grinding

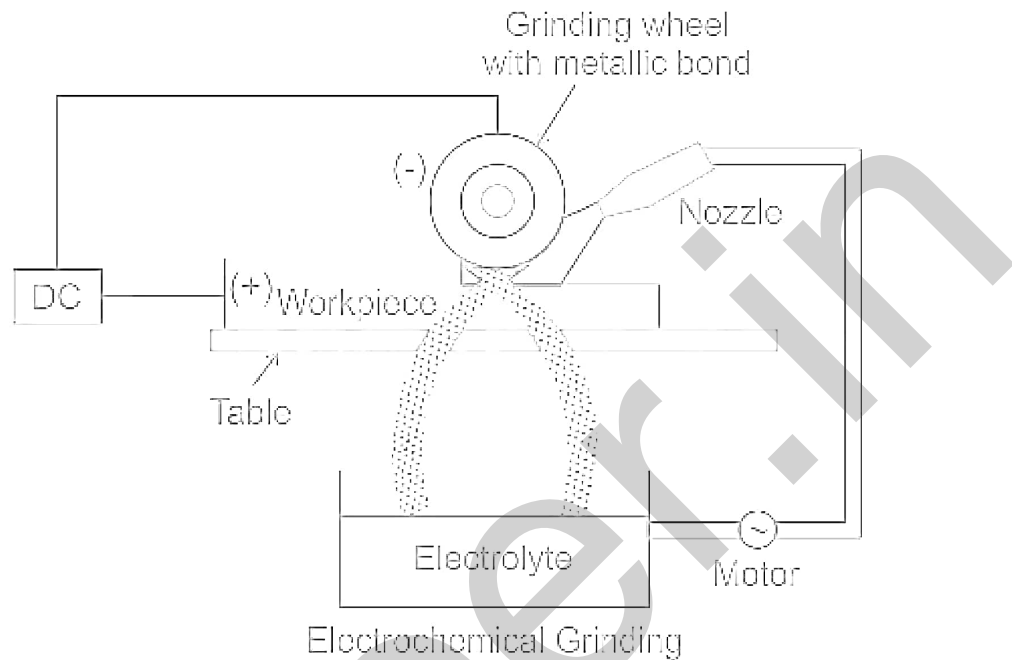

Work is machined by considered action of **electrochemical effect** (90%) and **conventional grinding** (10%)

- The material removal rate is **inversely proportional** to the Density of the workpiece material.
- A rotating **grinding wheel** will be used as a tool.
- The shaped tool is generally made of **brass ,copper ,bronze, or stainless steel** .
- The **electrolyte** is a highly conductive inorganic **salt solution** , such as **sodium chloride** mixed in water or **sodium nitrate** .
- It is **pumped** at a **high rate** through the passages in the tool.

The **penetration rate** of the tool is **proportional** to the **current density** .

85. Answer: b

**Explanation:**

Explanation :

When ice is **converted into the water** the particles in ice absorb heat energy during the process of conversion from ice to liquid water.

---

## Energy

- **Energy** is the **ability** of the body to do some **work** .
- The **unit** of energy is the same as that of work i.e. **Joule** (in S.I units).

### Conversion of water into Ice

- Molecules are constantly moving because they have **energy** .
- In a **liquid form** , water molecules have more energy than in a solid.
- They move around quickly, essentially bouncing off of one another
- As the liquid cools down, the amount of **potential energy** is reduced and the molecules start to move slower
- When the water temperature reaches around **0°C** , the molecules stick together and form a solid-ice.

### Conversion of ice into water

- The ice would **absorb energy** from the warmer air around them.
- This absorbed energy would facilitate them to overcome the **force of attraction** holding them together, enabling them to slip out of the fixed position that they held as ice.
- The process in which a solids change to a liquid is called **melting** .
- The melting point is the temperature at which a solids change to liquid.

### Important Points

The **maximum density** of water occurs at **4°C**

---

86. Answer: d

**Explanation:**

Explanation:

Lami's theorem is an equation relating the magnitudes of three coplanar, concurrent and non-collinear forces , which keeps an object in static equilibrium, with the

---

angles directly opposite to the corresponding forces. According to the theorem:

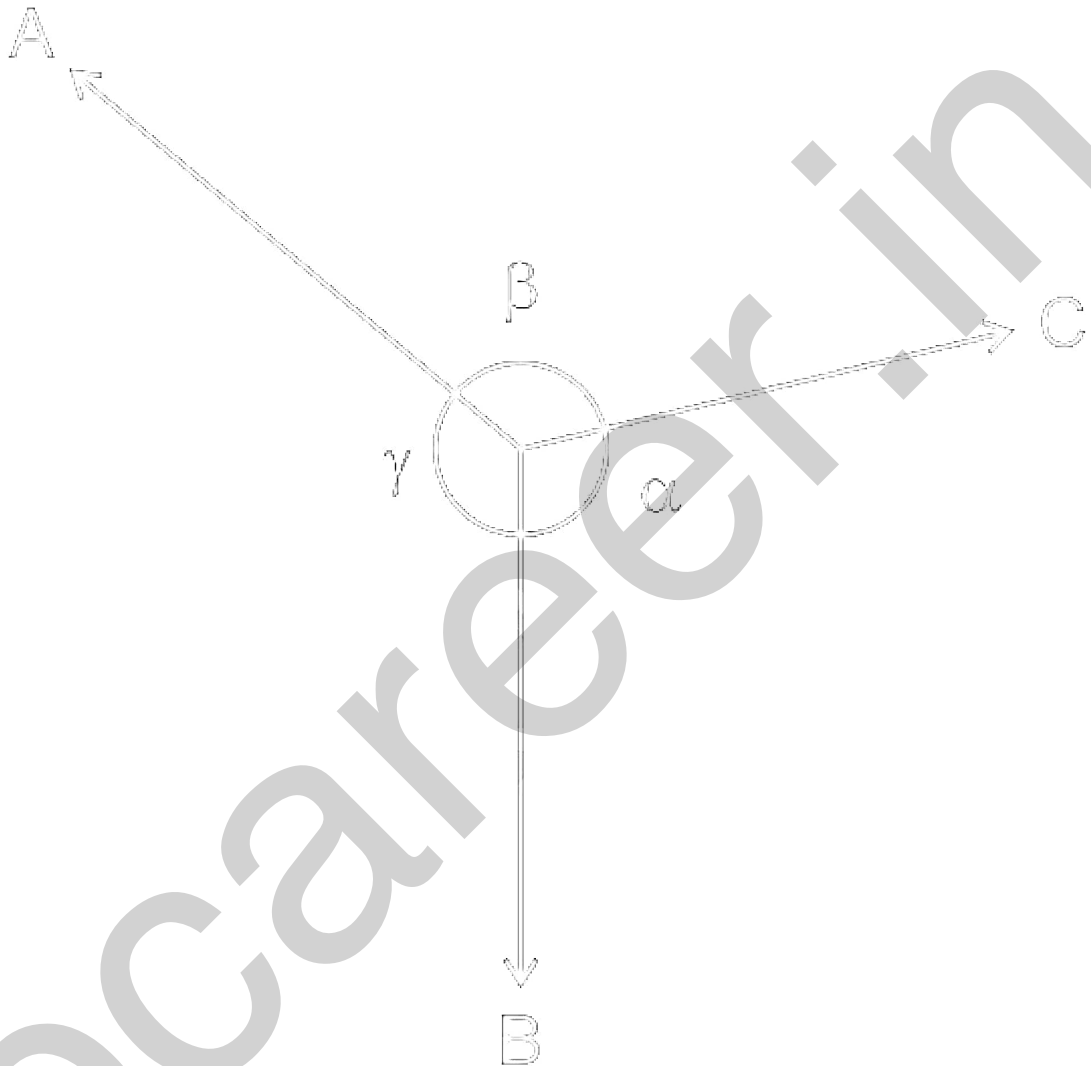

$$\frac{A}{\sin \alpha} = \frac{B}{\sin \beta} = \frac{C}{\sin \gamma}$$

### Important Points

Varignon's Principle of moments (or the law of moments):

It states, "If a number of coplanar forces are acting simultaneously on a particle, the algebraic sum of the moments of all the forces about any point is equal to the moment of their resultant force about the same point."

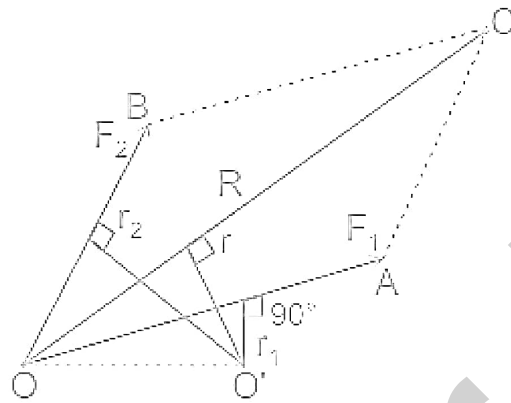

i.e.  $R \times r = F_1 \times r_1 + F_2 \times r_2$

---

87. Answer: b

Explanation:

Explanation:

- The dam is a type of stoppage or barrier is constructed to stop the flow of water.
  - Reservoirs with the dams will fulfil the water activities in nearby areas like **irrigation, household supply, industrial use, navigation and prevent flooding.**
  - Hydropower is associated with dams to produce electricity.
  - Reservoirs of dams also provide recreation for fishing and boating.
  - Types of the dams include arch dams, embankments dam, gravity dams etc.
  - Some of the examples are Tehri dam, Hirakud dam, Kallanai dam, Bhavani Sagar, Tungabhadra dam etc.
- 

88. Answer: c

Explanation:

Explanation:

- 
- Varnishes are a homogeneous colloidal solution of natural or synthetic resin in spirit or oil.
  - The varnish is used for both protection and decoration of metal surfaces.
  - Types of varnishes:
    - Spirit Varnish: It is prepared by dissolving natural or synthetic resins in a volatile solvent (spirit). This type of varnish dries just by the evaporation of the solvent.
    - The film formed is brittle and strong. It is used for polishing wooden surfaces.
    - Oil Varnish: It is prepared by dissolving natural or synthetic resins in **drying oil and volatile solvents**. This type of varnish dries by the evaporation of the solvent followed by oxidation and polymerisation of the drying oil.
    - Oil varnishes dry slowly, but the film is hard. It is used for interior and exterior works.

### Important Points

Characteristics of a good varnish:

- It should be soft
- It should produce a shiny and glossy film on drying
- It should dry quickly
- It should not shrink or crack after drying

---

89. Answer: d

**Explanation:**

Explanation:

Stiffness

- Stiffness of a material is the resistance offered to deformation, below the elastic limit.

- 
- A material with a high value of Young's modulus  $E$  is stiffer than the material with the lower value of Young's modulus.
  - Small values of  $E$  indicate flexible materials and a large value of  $E$  reflects stiffness and rigidity.

### Toughness

- The ability of the material to withstand stress (resist fracture due to high impact loads) without fracture is known as toughness.
- It is defined as the ability to absorb energy in the plastic state.

### Ductility

The property of the material that allows it to be drawn into wires or elongated before failure is known as ductility.

---

90. Answer: a

### Explanation:

#### Explanation:

#### Parkerizing

- It is a process of applying an anti-corrosion and lubricating phosphatized surface treatment.
- Parkerizing is an electrochemical process that creates a protective iron-phosphate layer on the outer surface of steel.
- Parkerizing, bonderizing, phosphating, or phosphatizing is a method of protecting a steel surface from corrosion and increasing its resistance to wear through the application of a chemical phosphate conversion coating.
- Parkerizing is usually considered to be an improved zinc or manganese **phosphating process**.
- Parkerizing is commonly used on firearms as a more effective alternative to protect against rust.



- 
- It is also used extensively on automobiles to protect unfinished metal parts from corrosion.
  - The Parkerizing process cannot be used on non-ferrous metals such as aluminium, brass, or copper.
  - It similarly cannot be applied to steels containing a large amount of nickel, or on stainless steel.

### **Important Points**

#### **Galvanization**

- In this method, a thin layer of zinc is applied to prevent corrosion of iron or steel.
- For example, shining iron nails, pins, etc.
- It is done to protect the metal from saltwater corrosion.

#### **Anodizing**

- It is used to provide a decorative and corrosion-resistant coating on aluminium and its alloys only.
- Anodizing is an electrochemical process that converts the metal surface into a decorative, durable, corrosion-resistant, anodic oxide finish.
- Aluminium ideally suited to anodizing, although other non-ferrous metals, such as magnesium and titanium.

---

**91. Answer: a**

**Explanation:**

**Explanation:**

**Couple**

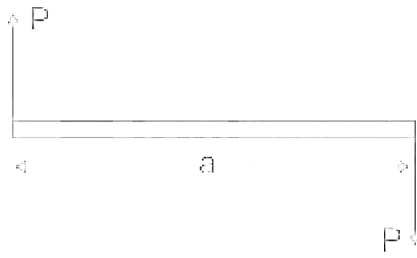

- When you use two hands to turn the **handlebars** of your **bicycle** or the **steering wheel** of your car you are applying two **parallel forces** to the same object.
- These two forces are not in equilibrium because they do not act in the same **straight line**.
- They are called a couple and have a **turning effect** or **moment**.

### Important Points

**Moment** – The moment of a couple is the **product of the magnitude** of one of the forces  $F$  and the **perpendicular distance**  $d$  between the two forces.

$M = \text{Force} \times \text{perpendicular distance}$

A couple is a **pair of force** acting on an object on an **object** which

- Are equal in **magnitude** and **opposite direction**
- Do not act along the same **straight line**
- Apply a moment to the object and so tend to turn it

Do not produce a single **resultant force** and so do not tend to move it from one position to another

---

92. Answer: a

### Explanation:

The correct answer is option 1 i.e. Cause-and-effect diagram.

Ishikawa diagrams are also known as fishbone diagrams, herringbone diagrams, cause-and-effect diagrams, or Fishikawa.

- 
- It was created by Kaoru Ishikawa, a Japanese economist in the 1960s and deals with the potential causes of a specific event.
  - Its basic concept was used in the 1920s
  - The diagram resembles a fish skeleton, with the "ribs" representing the causes of an event and the final outcome appearing at the head of the skeleton.
  - The purpose of the diagram is to allow management to determine which issues have to be addressed in order to gain or avoid a particular event.
  - Given below is a representation of the fishbone diagram:

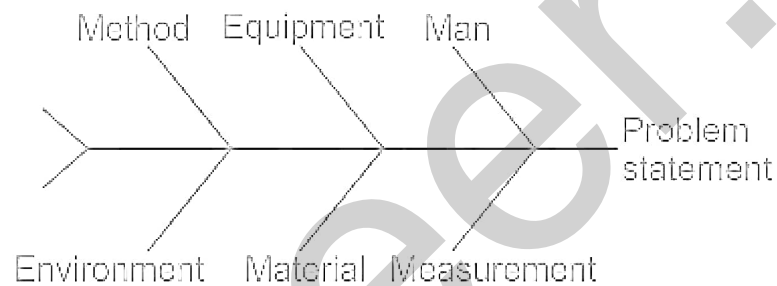

---

93. Answer: d

**Explanation:**

Concept:

Two-stroke engines: In this engine, one power stroke is obtained in each revolution of the crankshaft

Four-stroke engines: In this type of engine, one power stroke is obtained in two revolutions of the crankshaft

Four Stroke Engine	Two Stroke Engine
Four operations (suction, compression, power, and exhaust) take place in the four strokes of the piston	The four operations take place in two strokes of the piston
It gives one power stroke in the four strokes, i.e. in two revolutions of the crankshaft. As such three strokes are idle strokes	The power stroke takes place in every two strokes i.e. one power stroke for <b>one revolution of the crankshaft</b>
Due to more idle strokes and non-uniform load on the crankshaft, a heavier flywheel is required	The engine has a more uniform load as every time the piston comes down it is the power stroke. As such a lighter flywheel is used
The engine has more parts such as valves and its operating mechanism. Therefore, the engine is heavier	The engine has no valves and valve operating mechanism; Therefore, it is lighter in weight.
The engine is costlier as it has more parts	The engine is less expensive as it has a lesser number of parts
The engine efficiency is more as the charge gets completely burnt out. Consequently, fuel efficiency is more	The efficiency is less. A portion of the charge escapes through the exhaust port, and because of this, the fuel efficiency is less.

### Important Points

---

Advantages of the stroke engine over four-stroke engine are

- Low cost
- More uniform torque and hence lighter flywheel is needed
- Because of one power stroke for one revolution, power produced for same size of engine is more
- Lightweight and simplicity due to the absence of the valve mechanism.

---

94. Answer: b

**Explanation:**

The correct answer is Wetlands.

- Ramsar Convention is an international treaty for the conservation and sustainable utilization of wetlands, recognizing the fundamental ecological functions of wetlands.
- **The convention was adopted in Ramsar city of Iran in 1971**, hence the name is after the city.
- The members of these conventions follow three pillars:
  - Work towards the wise use of all their wetlands.
  - Designate suitable wetlands for the list of Wetlands of International Importance (the "Ramsar List") and ensure their effective management.
  - Cooperate internationally on transboundary wetlands, shared wetland systems and shared species.

**Additional Information**

- There are 49 Ramsar Wetland sites in India.
  - **Sundarbans wetland is the largest Ramsar Site of India.**
  - **Uttar Pradesh has the most number of Ramsar Sites in India.** Chilika Lake (Orissa) and Keoladeo National Park (Rajasthan) were recognized as the first Ramsar Sites of India.
-

---

95. Answer: c

**Explanation:**

Explanation:

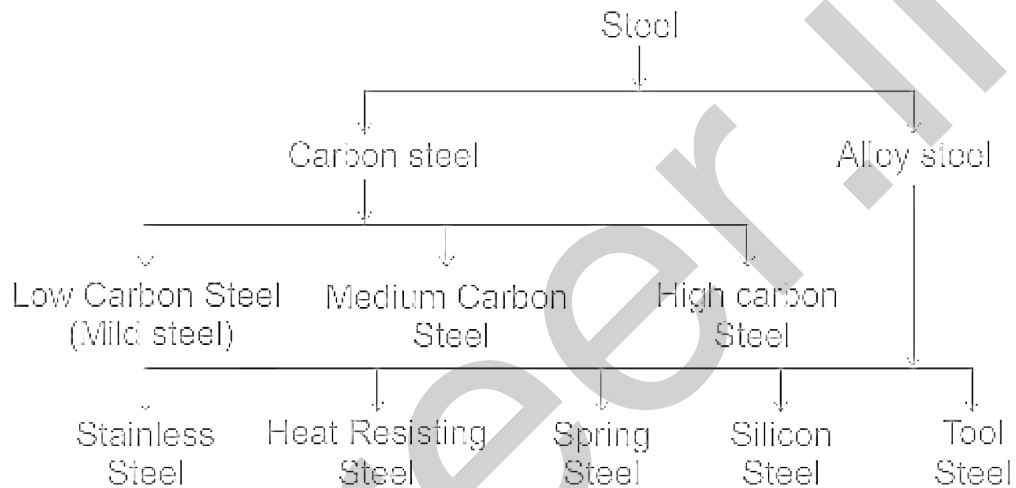

Low Carbon Steel (Mild Steel):

- Low carbon steel is an alloy of iron and carbon. The carbon content varies from 0.05 to 0.15 % for dead mild steel and 0.15 to 0.3 % for mild steel.
- The dead mild steel is very much ductile and is used for making various components like sheets, strips, wires, rods etc.
- The mild steel is soft and ductile. It is used for making various structural sections like angles, channels, beams, rods, pins, etc.

Medium carbon steel:

- For medium carbon steel, the carbon percentage varies from 0.3 to 0.8%. These steels have better strength and not very easy to shape as mild steel. The hardness is slightly higher, and ductility is poor.
- The machine parts requiring strength like springs, automobile parts, shafts, dies for forging etc. are made from medium carbon steel.

High Carbon steel:

- The carbon percentage varies from 0.8 to 1.5. A high percentage of carbon gives hardness and strength to the metal.

- 
- It is mainly used for tools like chisels, hammers, dies, punches, broaches, reamers, drills, taps, etc. and the machine parts like springs, mandrels and similar parts requiring high strength and hardness.

High-speed steel (HSS):

- This is high alloy steel which can be used to cut metal at a cutting speed of 2 to 3 times that of high carbon steel.
  - The most commonly used HSS has a composition called 18 – 4 – 1 i.e. tungsten 18%, chromium 4%, vanadium 1%.
  - The HSS is used for cutting tools in lathes, shapers, planers, milling machines, drilling machines, broaching machines etc.
- 

96. Answer: c

**Explanation:**

Explanation:

Angular measurement involves the measurement of angles of tapers and similar surfaces. Examples:

- **Bevel protector**
- **Sine Bar**
- Spirit level
- Clinometer
- **Autocollimators**

Bevel protector:

- Bevel protector is used for measuring the angles between two faces of components.

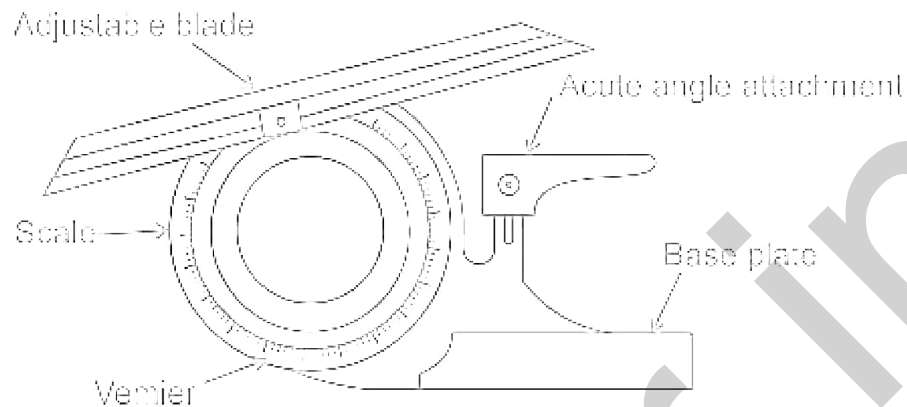

- It has a base plate or stock whose surface has a high degree of flatness and surface finish.
- The stock is placed on the workpiece whose angle is to be measured. It is normally used as a reference base for measuring angles.
- An adjustable blade attached to a circular dial is made to coincide with the angular surface.
- It can be swiveled to the required angle and can be locked.

### Sine bar

- A sine bar is a precision measuring instrument for checking and setting of angles.
- The size of a sine bar is specified by its length.
- The length of the sine bar is the distance between the centers of the rollers.
- A sine bar is used to measure angles based on the sine principle.
- Its upper surface forms the hypotenuse of a triangle formed by a steel bar terminating in a cylinder near each end.
- When one of the cylinders, called a roller, is resting on a flat surface, the bar can be set at any desired angle by simply raising the second cylinder.
- The required angle is obtained when the difference in height between the two rollers is equal to the sine of the angle multiplied by the distance between the centers of the rollers.

$$\sin \theta = \frac{h}{L}$$



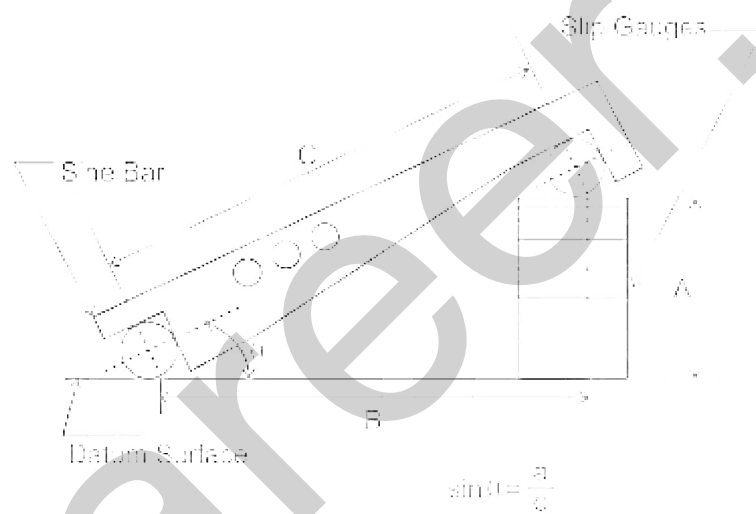
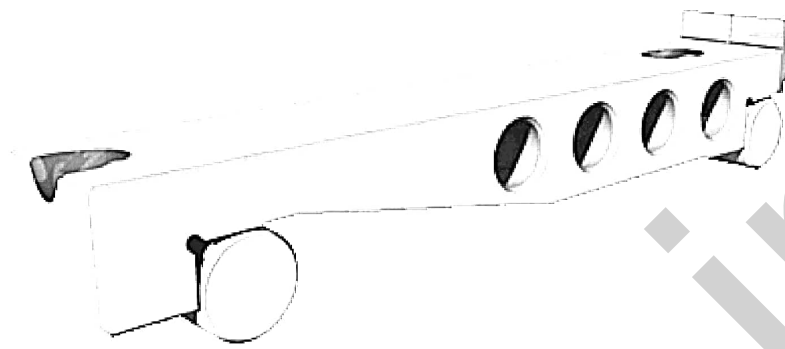

### Autocollimator

- An autocollimator is an optical instrument that is used to measure small angles with very high sensitivity.
- The autocollimator has a wide variety of applications including precision alignment, detection of angular movement, verification of angle standards, and angular monitoring over long periods.
- An autocollimator is essentially an infinity telescope and a collimator combined into one instrument.

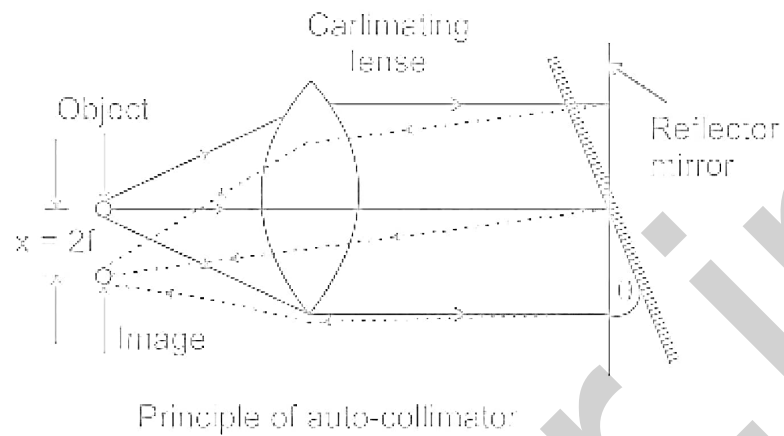

### Micrometer

- A micrometer is a precision instrument used to measure a job, generally within an accuracy of 0.01 mm.
- Micrometers used to take the outside measurements are known as outside micrometers.

97. Answer: b

### Explanation:

#### Concept:

The maximum load at which the column tends to have lateral displacement or tends to buckle is known as buckling or crippling load. Load columns can be analyzed with the Euler's column formulas can be given as

$$P = \frac{n^2 \pi^2 EI}{L^2}$$

- For both end hinged,  $n = 1$
- For one end fixed and other free,  $n = 1/2$
- For both end fixed,  $n = 2$
- For one end fixed and other hinged,  $n = \sqrt{2}$

Effective Length:

---

$$L_{eq} = \frac{L}{n}$$

Calculation:

Given, for both ends fixed columns  $n = 1$

Therefore,  $L_{eq} = \frac{L}{1} = L$

---

98. Answer: b

**Explanation:**

The correct answer is option 2 i.e., **1638**

- The **maximum font-size** available in **Microsoft Word 2010** from the dropdown list is **72**; however, the font size can be set up to **1638** by typing the size manually for the font.
  - Microsoft Word is a word processor developed by Microsoft.
  - It was released on October 25, 1983, under the name Multi-Tool Word for Xenix system.
  - The commercial version of Word is licensed as a standalone product or as a component of Microsoft Office or Windows RT.
  - Microsoft Office is a family of client software, server software, and services developed by Microsoft.
  - The current on-premises, the desktop version of Office is Office 2019, released on September 24, 2018.
- 

99. Answer: a

**Explanation:**

**Concept :**

$$\text{Dryness Fraction } (x) = \frac{\text{Mass of dry vapor in the wet steam}}{\text{Total mass of wet steam}}$$

---

**Calculation:**

**Given:**

Mass of dry vapor = 0.8 kg, Mass of moisture = 0.2 kg

The total mass of wet steam = 1 kg

Dryness fraction is:

$$x = \frac{\text{Mass of dry vapor in the wet steam}}{\text{Total mass of wet steam}}$$

$$x = \frac{0.8}{1} = 0.8$$

**Important Points**

- **Dryness fraction** defines the **quality** of wet steam.
  - For the **saturated liquid**, the value of dryness fraction is **zero**.
  - For the **dry saturated steam**, its value is **unity**.
  - It also can be defined as the part of the **latent heat** absorbed by the steam at a given **pressure** to reach the existing condition.
- 

100. Answer: d

**Explanation:**

**Explanation:**

- The flow in manufacturing is a technique by which products are manufactured one unit at a time, at a formulated rate, without waiting time, queue time, or other delays.

**Continuous production**

- In this, the production activity continues for 24 hours or on three shifts a day basis.

- 
- A steel plant, the gas plant belongs to this type. It is impossible to stop the production process on short notice without causing great damage to its furnace and related equipment.

**Mass production and Flow production belong to continuous type only.**

### **Flow production**

- In this type, the plant, its equipment, and layout have been chiefly designed to produce a particular type of product.
  - Flexibility is limited to minor modifications in the layout or design of models.
  - Some famous examples are automobiles, engines, house-hold machinery, chemical plants, gas and oil plants, etc.
- 

**101. Answer: c**

### **Explanation:**

The correct answer is Seiso.

#### **Important Points**

- 5S represents Japanese words that **describe the steps of a workplace organization process**.
- They are **Seiri, Seiton, Seiso, Seiketsu, Shitsuke**.
  - **Seiri (Sort):** remove items that are no longer needed (sort).
  - **Seiton (Straighten, Set):** organize the items to optimize efficiency and flow (straighten).
  - **Seiso (Shine, Sweep):** clean the area to more easily identify problems (shine).
  - **Seiketsu (Standardize):** implement color coding and labels to stay consistent with other areas (standardize).
  - **Shitsuke (Sustain):** develop behaviors that keep the workplace organized over the long term (sustain).
- A new 'S' is added, that is **Safety or Security**. It becomes 6s.

---

### Key Points

- 5S is based on the CANDO system developed by Henry Ford in the early 20th century.
- 

102. Answer: c

### Explanation:

#### Explanation :

A Meander drive uses a **three-shaft mechanism** consisting of identical double **cluster gears** and a **sliding carrier** with a **tumbler gear** or the carrier may have only one sliding block.

Feed gearboxes are of various types, classified as

- **change gear** on a fixed position
- **sliding gears**
- **intermeshing gear cones and sliding gears**
- the tumbler gearbox of **Norton type**
- **meander type** with one sliding gear or tumbler

#### Meander Drive

- It is the most commonly used **feed gearbox**
  - In the cases of sliding block, the system requires more cluster gears to have the same requisite number of speeds obtained by using **tumbler gears**
  - It has more **reliability** and increased **rigidity** of the system
  - This drive uses two separate **motors** having reverse traverse whenever needed using a reversible clutch.
- 

103. Answer: c

## Explanation:

The correct answer is Na.

- The decreasing order of atomic radius is Na (227pm) > P (195pm) > S (180pm) > Cl (175pm) .

## Explanation:

- When two atoms have the same value of n for the valence electrons, the atom with the **greater number of protons** will generally have a **greater effective nuclear charge** to draw the valence electrons closer to the nucleus and, thus, decrease the atomic radius .
- Since **chlorine's 17 protons** are **greater** than **sodium's 11 protons** ,chlorine will have a **greater effective nuclear charge** to draw **chlorine's valence electrons closer to the nucleus** and, thus, **chlorine** is expected to **have a smaller atomic radius**.
- While **sodium** with the **lower effective nuclear charge** is expected to have a **larger atomic radius** .

## Important Points

- In the periodic table, the atomic radius of elements tends to decrease as you move across a row from left to right.
- Ionic radii increase down a group as more shells are added.

ELEMENT	ATOMIC NUMBER	GROUP / PERIOD
Na (Sodium)	11	1 / 3
P (Phosphorus)	15	15 / 3
S (Sulphur)	16	16 / 3
Cl (Chlorine)	17	17 / 3

## Key Points

- 
- **Sodium is highly reactive** so that it is stored in oil or kerosene because it spontaneously ignites in water.
  - At room temperature, sodium metal is soft enough that you can cut it with a butter knife.
  - White phosphorus is used in flares and incendiary devices.
  - Red phosphorus is in the material stuck on the side of matchboxes, used to strike against safety matches to light them.
- 

104. Answer: a

**Explanation:**

Calculation:-

Given:-

$$P = 20 \text{ kN}, \theta = 60^\circ$$

$$\cos \theta = \frac{\text{base}}{\text{Hypotenuse}}$$

$$\cos 60^\circ = \frac{OX}{OP}$$

$$\frac{1}{2} = \frac{OX}{20}$$

$$OX = 10 \text{ kN}$$



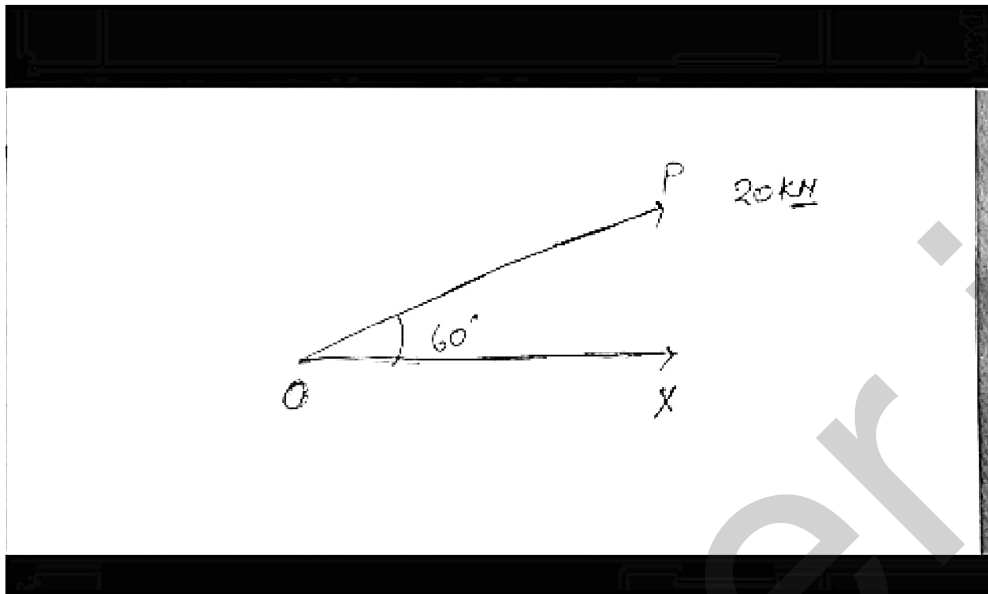

105. Answer: c

### Explanation:

#### Explanation:

The purpose of all the comparator gauges is to indicate the difference in the size between the standard (slip gauge or ring gauge) and the work being measured by means of some form of pointer on a scale at a magnification which is enough to read to the level of accuracy required.

The following principles are employed in the commonly used comparator gauges.

#### Mechanical comparator

Mechanical comparator employs mechanical means like levers, gear train etc. for magnifying all deviation of the measurement. Example:

- Johansson Mikrokator
- Sigma Comparator
- Mechanical - Optical Comparator
- 'Red' comparator

---

### Important Points

#### Electronics comparator

It works by using step up, step down transformers. The electrical comparator generally depends on the Wheatstone bridge principle. Electrical comparators have no moving parts. Thus, a high degree of reliability is expected from these instruments.

#### Pneumatic comparator

Pneumatic comparator works by using high-pressure air, valves, back pressure etc. It works on the principle of pressure difference generated by the air flow. This comparator is fast, rigid, accurate and suitable for use on the shop floor, especially in mass production.

#### Optical comparator

Optical comparator works by using a lens, mirrors, light source etc. These instruments employ the principle of reflection of light rays. Very large magnifications are attainable, and the instrument is free from friction and backlash. Accuracy of measurements up to  $1\mu$  is possible.

---

106. Answer: b

#### **Explanation:**

##### Explanation:-

#### **Maximum Shear Stress Theory ( MSST )**

- According to this theory, failure occurs when maximum shear stress at any point reaches the yield strength.
- Condition for safe design:

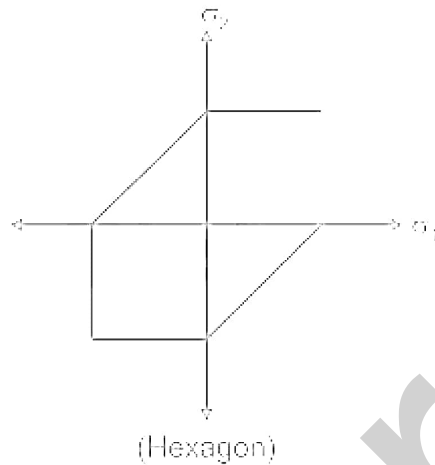

$$\tau_{max} \leq \frac{S_{ys}}{N} = \frac{S_{yt}}{2N}$$

For tri-axial state of stress,

$$Max \left\{ \left| \frac{\sigma_1 - \sigma_2}{2} \right|, \left| \frac{\sigma_2 - \sigma_3}{2} \right|, \left| \frac{\sigma_3 - \sigma_1}{2} \right| \right\} \leq \frac{S_{yt}}{2N}$$

For bi-axial state of stress,

$$Max \left\{ \left| \frac{\sigma_1 - \sigma_2}{2} \right|, \left| \frac{\sigma_2}{2} \right|, \left| \frac{\sigma_3}{2} \right| \right\} \leq \frac{S_{yt}}{2N}$$

- This theory is well suitable for ductile materials.
- MSST is not suitable for hydrostatic loading.

### Important Points

For brittle material

Theories of failure	Shape
Maximum Principal Stress theory (RANKINE'S THEORY)	Square
Maximum Principal Strain theory (St. VENANT'S THEORY)	Rhombus
Total Strain Energy theory (HAIGH'S THEORY)	Ellipse

---

**For Ductile material**

Theories of failure	Shape
Maximum Shear Stress Theory (GUEST AND TRESCA'S THEORY)	Hexagon
Maximum Distortion Energy Theory (VON MISES AND HENCKY'S THEORY)	Ellipse

---

107. Answer: a

**Explanation:**

Explanation:-

Edges of optical flats are generally **beveled** to  $45^\circ$  by suitable grinding and polishing to make **edges** free from any chips.

Optical flats are cylindrical with the working surfaces flat and are of two types

**Type A**

- It has only one surface flat.
- The working surface of this type of flat is indicated by an arrowhead on the cylindrical surface pointing towards the working surface.
- It is used for testing the flatness of precision measuring surfaces of flats, slip gauges, measuring tables, etc.

**Type B**

- It has both surfaces flat and parallel to each other.
- It is used for testing measuring surfaces of micrometers, measuring anvils, and similar length measuring devices for testing flatness and parallelism.

---

---

108. Answer: b

**Explanation:**

Explanation:

Intensive Property: These are the properties of the system which are independent of mass under consideration.

e.g. Pressure, Temperature, density, Specific enthalpy, Melting point, Boiling point, etc.

Extensive Properties : The properties which depend on the mass of the system under consideration.

e.g Internal Energy, Enthalpy, **Volume** , Entropy etc.

Note: All specific properties are intensive properties. For e.g. specific volume, specific entropy etc.

$$\begin{array}{|c|} \hline m, v, T, P, \rho \\ \hline \end{array} \longrightarrow \begin{array}{|c|c|} \hline \frac{m}{2}, \frac{v}{2} & \frac{m}{2}, \frac{v}{2} \\ \hline T, P, \rho & T, P, \rho \\ \hline \end{array}$$

thus, Density is not an extensive property.

---

109. Answer: b

**Explanation:**

Explanation:

**Resilience**

- Resilience is the total strain energy stored in a given volume of a material within elastic limit.

- 
- On removal of load this energy is released. In other words, it is the area under load-deflection curve within elastic limit.

### Ductility

- The property of material by virtue of which, it can be drawn in to wire with the application tensile force is known as ductility.
- It is measured as the ratio of elongation of the material at the fracture during the tensile test to the original length, expressed as percentage.
- It may also be expressed as the ratio of reduction in cross-sectional area in the fractured specimen to the original cross-section area.

### Toughness

- It is defined as the ability of the material to absorb energy before fracture takes place.
- This property is essential for machine components which are required to withstand impact loads.
- Tough materials have the ability to bend, twist or stretch before failure takes place.

---

110. Answer: a

### Explanation:

The correct answer is Unreliable supply.

- Most renewable energy resources are clean because they do not produce any pollution.
- Most renewable energies are cheap because their energy supplies do not have any cost.

### Important Points

ENERGY SOURCE	ADVANTAGE	DISADVANTAGE
Wind turbines	Clean and cheap to run.	Expensive to set up and the wind does not always blow.
Tidal generators	Clean and cheap to run and produce a lot of electricity once running.	Very expensive to set up and could be hazardous to local wildlife.
Hydroelectric power stations	Clean and cheap to run.	Expensive to set up and output could be affected by drought.
Solar cells	Clean and cheap to run.	Not always sunny and output does not always outweigh the initial cost to set up.

### 111. Answer: a

#### Explanation:

##### Concept:

##### Moment of inertia:

- Moment of inertia of a rigid body about a fixed axis is defined as the sum of the product of the masses of the particles constituting the body and the square of their respective distances from the axis of the rotation .
- Moment of inertia of a particle is

$$I = mr^2$$

Where  $r$  = the perpendicular distance of the particle from the rotational axis.

- Moment of inertia of a body made up of a number of particles (discrete distribution)

$$I = m_1 r_1^2 + m_2 r_2^2 + m_3 r_3^2 + m_4 r_4^2 + \dots$$

- The moment of inertia of a solid cylinder of mass 'M' and radius 'R' about the axis of the cylinder

$$\Rightarrow I = \frac{MR^2}{2}$$

### Important Points

Body	Axis of Rotation	Moment of inertia
Uniform circular ring of radius R	perpendicular to its plane and through the center	$MR^2$
Uniform circular ring of radius R	diameter	$\frac{MR^2}{2}$
Uniform circular disc of radius R	perpendicular to its plane and through the center	$\frac{MR^2}{2}$
Uniform circular disc of radius R	diameter	$\frac{MR^2}{4}$
A solid sphere of radius R	diameter	$\frac{2}{5}MR^2$
A hollow sphere of radius R	diameter	$\frac{2}{3}MR^2$
A hollow cylinder of radius R	Axis of cylinder	$MR^2$



---

112. Answer: a

**Explanation:**

Explanation:-

- A metrological **grating** is a scale having a large number of equally spaced parallel lines.
- The two transparent **gratings** are put one over the other.

Important Points

- Scales have lines marked on them that are rulings.
  - Scales are usually made of steel. Lines in scales are spaced far apart so that interpolating devices e.g. Vernier device is used to make accurate settings.
  - Gratings play an important role in rotary as well as linear measurements.
- 

113. Answer: d

**Explanation:**

Explanation:

- Bollywood celebrated 63rd Jio Filmfare Awards 2018, held in Mumbai.
  - '**Hindi Medium**' bagged honours in the categories of Best Film and Best Actor in a Leading Role (Male) for Irrfan Khan's impeccable performance.
  - Vidya Balan won her career's sixth Filmfare award for her passionate portrayal of a middle-aged homemaker who turns into a radio jockey in 'Tumhari Sulu'.
- 

114. Answer: b

**Explanation:**

Explanation:-

- 
- **The velocity of approaches** is defined as the velocity with which the water approaches or reaches the weir or notch before it flows over it.
  - The whirl velocity is the tangential component of absolute velocity at the blade inlet and outlet. This component of velocity is responsible for the whirling or rotating of the turbine rotor.
  - Shear velocity also called friction velocity. It is useful as a method in fluid mechanics to compare true velocities.
- 

**115. Answer: c**

**Explanation:**

The correct answer is Magnetisation.

Explanation:

- Magnetic storage is one of the most affordable ways to store large amounts of data.
  - Magnetic storage uses the two types of magnetic polarities to represent the binary information consisting of zeros and ones.
  - Magnetic storage devices store data by magnetizing particles on a disk or tape. Commonly used devices that use magnetic storage include magnetic tape, floppy disks and hard-disk drives.
  - The hard disk is a spindle of magnetic disks, called platters, that record and store information. Because the data is stored magnetically, information recorded to the hard disk remains intact after you turn your computer off.
  - An example of a hard drive is the location on a desktop computer where a person could save their research paper.
  - IBM made the first commercial hard disk drive-based computer and called it RAMAC – short for “Random Access Method of Accounting And Control.”
- 

**116. Answer: a**

---

## Explanation:

### Explanation:-

#### Lapping

- It is used to produce finished surfaces. It gives a very high degree of accuracy and smoothness.
- It is used in the production of optical lenses, metallic bearing surfaces, measuring gauges, surface plates, and other measuring instruments.
- Machine lapping is recognized as a fast lapping process.
- In machine lapping, pressure up to  $0.02 \text{ N/mm}^2$  for soft material and  $0.5 \text{ N/mm}^2$  for hard material is applied.

#### Additional Information

- **Honing** is a finishing process, in which a tool called hone carries out a combined rotary and reciprocating motion while the workpiece does not perform any working motion. The surface finish of the cylindrical hole is maintained by honing.
- **Filing** a file is a piece of very hard steel that has a series of parallel grooves cut into it, which leave behind rows of sharp cutting teeth. Files are typically used by hand.
- **Buffing** is similar to polishing in appearance, but its function is different. Buffing is used to provide attractive surfaces with high luster.

---

117. Answer: c

### Explanation:

The correct answer is Reflection on roadway.

- **Diffuse reflection** is the reflection of light from a surface where an incident ray is reflected at many angles.
- For the diffuse reflection, everything we see around us is visible.
- Examples of diffuse reflections are **bicycle reflectors, clothing, paper**.

---

### Key Points

- Two types of reflection: **diffuse reflection** and **specular reflection** .
  - **Specular reflection** is defined as **light reflected from a smooth surface at a definite angle or in a single direction** . Examples, **reflection on the mirror, still water, etc.**
  - The law of reflection states that when a ray of light reflects off a surface, the angle of incidence is equal to the angle of reflection.
- 

118. Answer: b

**Explanation:**

Explanation:-

- **The electromagnetic force** is a type of physical interaction that occurs between electrically charged particles.
- It acts between charged particles and is the combination of all magnetic and electrical forces.
- The electromagnetic force can be attractive or repulsive.
- **A pinch welding gives narrow and long flame which is concentrated on the desired part, it is achieving by an induction coil, which results in electromagnetic forces.**

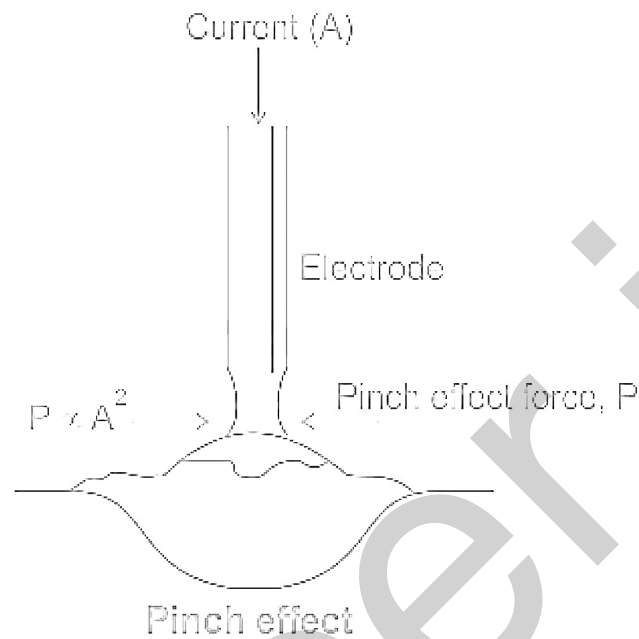

### Important Points

Arc blow is the undesirable effect of arc, during arc welding.

---

119. Answer: d

**Explanation:**

Explanation:-

**Unit Load Principle:** Handle product in a unit load as large as possible.

**Pallet**

- A pallet is a horizontal platform typically affixed to a superstructure and a bottom deck.
- It allows it to be lifted and moved by material handling equipment such as lift trucks and conveyors, and transport vehicles.
- The pallet provides the base for assembling, storing, handling, and transporting materials and products.
- The pallet is the most common base for the unit load.

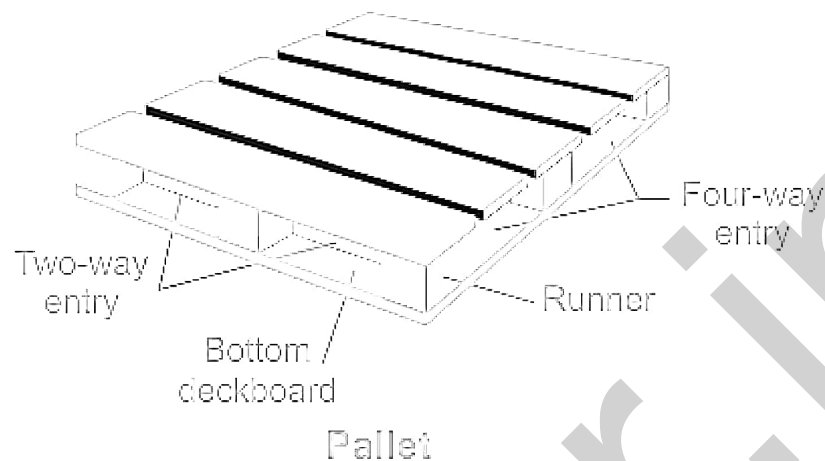

### Important Points

- **Space Utilization Principle:** Encourage effective utilization of all the space available
- **Gravity Principle:** Encourages usage of gravity principle in the movement of goods.
- **System Flow Principle:** Encourages integration of data flow with physical material flow

---

120. Answer: d

### **Explanation:**

The correct answer is Simplex.

### Additional Information

- Communication between a computer and a keyboard involves simplex transmission because here data flows in a single direction.
  - Simplex transmission is a type of transmission mode. In this type of transmission mode, **data can be sent only through one direction** i.e. communication is unidirectional. We cannot send a message back to the sender.
  - Examples of simplex Mode is the **loudspeaker, television broadcasting, television and remote, keyboard and monitor** etc.

- 
- In **half-duplex mode**, each station can both transmit and receive, but not at the same time, that is, when one device is sending, the other can only receive, and vice versa. Example of **Half-duplex systems: Walkie-talkies and CB (citizens band) radios**.
  - In **full-duplex mode**, both stations can transmit and receive simultaneously.
    - **Telephone** is an example of a full-duplex system.
- 

121. Answer: c

**Explanation:**

Concept:

- Moment of Inertia (I) : Moment of inertia is the inertia of a rotating body concerning its rotation. Moment of inertia is also known as rotational inertia.
  - $I = \sum MR^2$  Where I is the moment of inertia of the body, M is the mass of the body, R is the radius
  - SI unit is  $\text{kgm}^2$ .
  - Dimension formula is  $[M L^2 T^0]$ .
  - The SI unit of the moment of inertia is  $\text{kgm}^2$ .
- 

122. Answer: a

**Explanation:**

- Shri Arun Jaitley, Union Minister of Finance & Corporate Affairs, released a book titled 'Mann Ki Baat - A Social Revolution on Radio' in New Delhi.
- The book is based on 50 episodes of Prime Minister Shri Narendra Modi's heart to heart talk with the citizens of India, Man Ki Baat.
- The book also gives insight into behind the scene research work done on the massive public feedback received through various channels after every episode of Mann Ki Baat.

---

---

123. Answer: c

**Explanation:**

Concept:

- Gantt charts are mainly used to allocate resources to activities.
- The resources allocated to activities include staff, hardware, and software. Gantt charts are useful for resource planning.
- A Gantt chart is a special type of bar chart where each bar represents an activity.
- This chart lists the tasks to be performed on the vertical axis, and time intervals on the horizontal axis.
- The bars are drawn along a timeline. The length of each bar is proportional to the duration of time planned for the corresponding activity.
- With the use of this chart, we can check the progress of project with
  - A visual display of the whole project,
  - Timelines and deadlines of all tasks,
  - Relationships and dependencies between the various activities,
  - Project phases



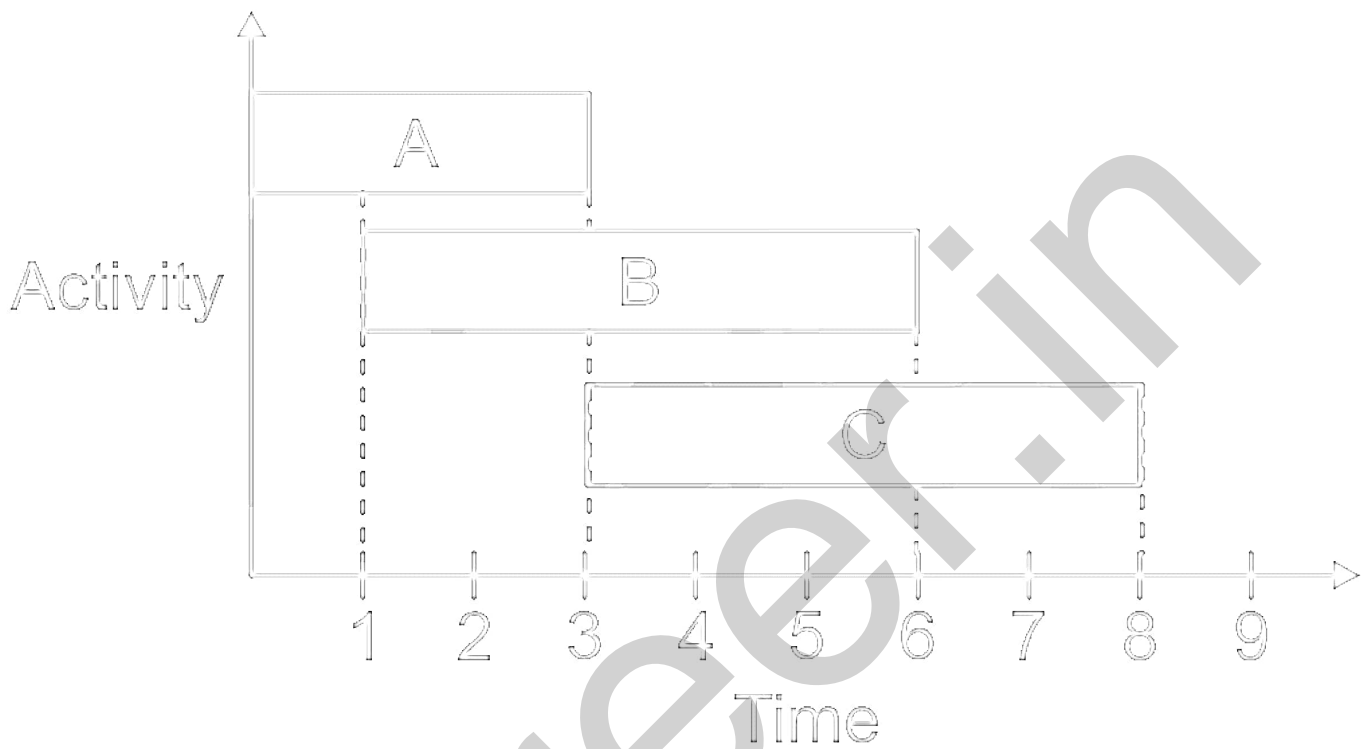

124. Answer: a

**Explanation:**

Concept:

- Projectile motion: Projectile motion is the motion of an object projected into the air, under only the acceleration of gravity. The object is called a projectile, and its path is called its trajectory.
- Initial Velocity: The initial velocity can be given as x components and y components.
- Component of initial velocity in x-direction,  $(u_x) = u \cos \theta$
- Component of initial velocity in the y-direction,  $(u_y) = u \sin \theta$
- In the case of projectile motion, we can see a free-fall motion of a body on a parabolic path with constant velocity.
- If a body is thrown at a certain angle then during its movement, we get two components of velocity as given below.

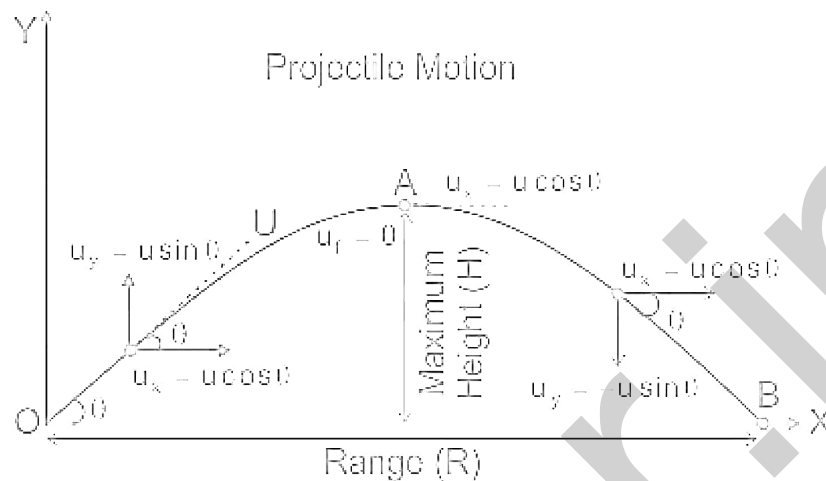

- And thus, the range of a projectile is the displacement of a particle along the x-axis and can be given as:

The range of the projectile,

- Whereas the time of flight is the total time for which projectile stayed in the air.

Time of flight for the projectile,  $(R) = u \cos \theta \times t$

The angle of projection =  $\theta$

Initial velocity =  $u$

Gravitational acceleration =  $g$

Time of flight =  $t$

Range of projectile =  $R$

Explanation:

As given above,

$v$  = initial velocity of projectile

$\theta$  = angle with x-axis

Time of flight for the projectile,  $(t) = \frac{2v \sin \theta}{g}$

And the range of the projectile,  $(R) = v \cos \theta \times t$

---

Thus, by comparing the above two equation range of projectile can also be modified as

$$R = v \cos \theta \times \frac{2v \sin \theta}{g} \Rightarrow R = \frac{2v^2 \sin \theta \cos \theta}{g}$$

But  $2 \sin \theta \cdot \cos \theta = \sin 2\theta$  (By using trigonometric relation)

$$\Rightarrow R = \frac{v^2 \sin 2\theta}{g}$$

---

125. Answer: b

**Explanation:**

Explanation:

- Asperities between touching plates the resistance of the joint R is a complex fact to know because it is compared of
    - The resistance of the electrode
    - The contact resistance between the electrode and the workpiece
    - The contact resistance between the two workpiece plates
    - The resistance of the workpiece plates
  - The amount of heat released is directly proportional to the resistance.
  - It is likely to be released at all of the above-mentioned points, but the only place where a large amount of heat is to be generated to have an effective fusion is **at the interface between the two workpiece plates.**
  - Therefore, the rest of the component resistance should be made as small as possible, since the heat released at these places would not aid in welding.
  - The critical variable in a resistance welding process is the contact resistance between the two workpiece plates and their resistance themselves.
  - The contact resistance is affected by the surface finish on the plates since the rougher surface has higher contact resistance.
- 

126. Answer: c

---

## Explanation:

### CONCEPT:

- Solar cooker: It is a device that uses the energy of sunlight to heat or cook food
- A concave mirror is that mirror whose reflecting surface is toward the center of the curvature. It is also known as a converging mirror.

### EXPLANATION:

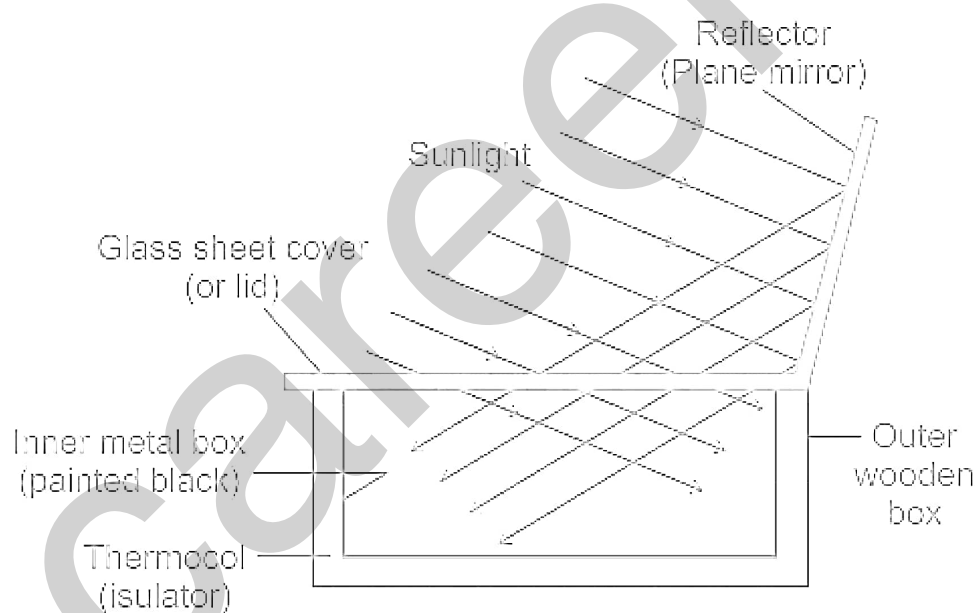

- A solar cooker contains a box made of insulating material, with its inner surfaces blackened. The top is closed by a glass sheet.
- **Glass sheet** present in the **solar cooker** easily passes the **radiation into the solar cooker** and the **radiation gets absorbed** and **cannot pass back out through the glass**.
- Thus, the **glass sheet** produces a **greenhouse effect** in the solar cooker. Therefore option 3 is correct.

---

127. Answer: a

## Explanation:

## Explanation:

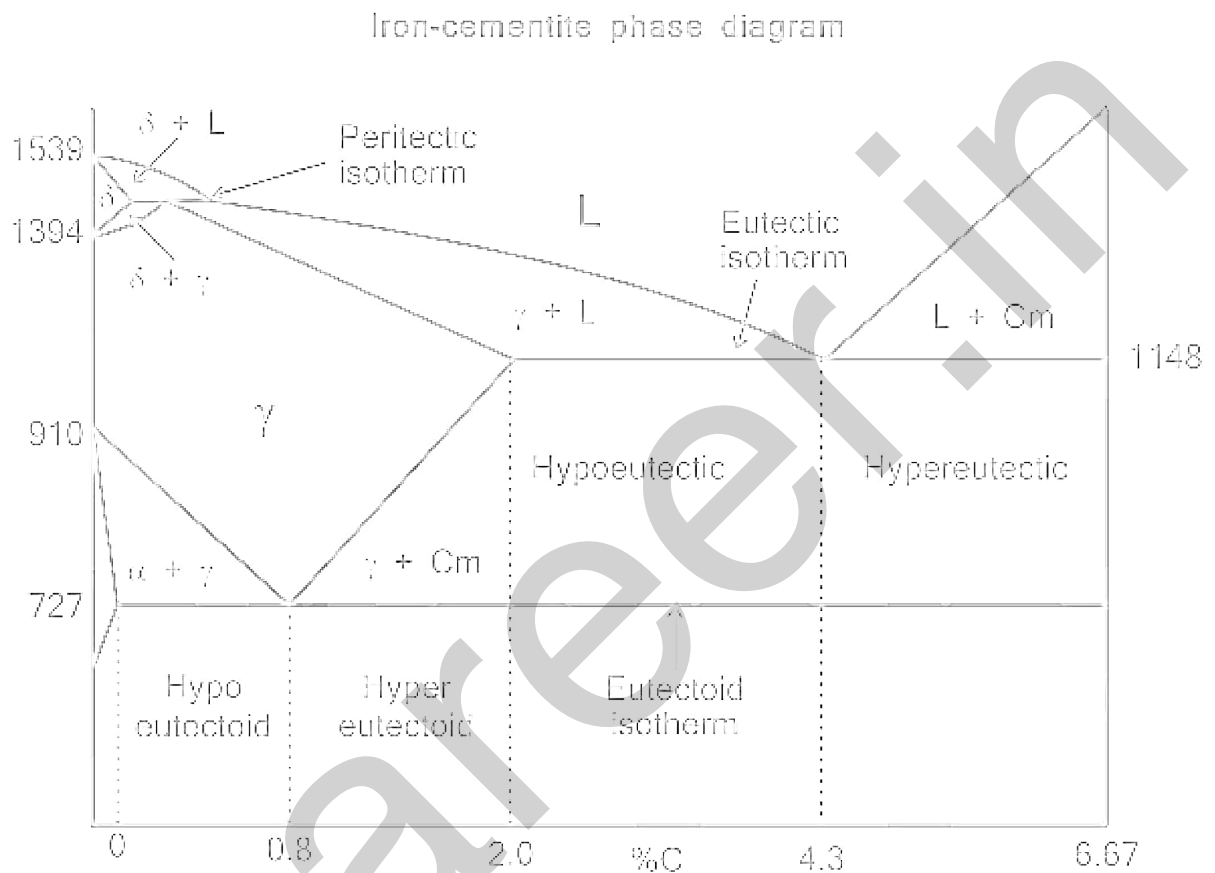

**Critical temperature:** The temperature at which phase change of any substance happens.

**Lower critical temperature :**

- The lower critical temperature of all steels is the same i.e. 723 °C.
- It is the temperature of Pearlite to Austenite transformation.
- Below this temperature austenite does not exist.

**Hypo-eutectoid steels :**

- Carbon content from 0 – 0.83 % consists of primary ferrite (according to the curve A<sub>3</sub>) and Pearlite.

**Eutectoid steel :**

- Carbon content 0.83 % entirely consists of pearlite.

---

### Hyper-eutectoid steels :

- Carbon content from 0.83 – 2.06 % consists of primary cementite (according to the curve  $A_{cm}$ ) and pearlite.

### Upper critical temperature (Point $A_3$ ):

- It is the temperature below which ferrite starts to form as a result of ejection from austenite in the hypo-eutectoid alloys.

### Upper critical temperature (Point $A_{cm}$ ):

- It is the temperature below which cementite starts to form as a result of ejection from austenite in the hyper-eutectoid alloys.
- 

128. Answer: a

### Explanation:

#### Explanation:

- Immersion in molten material is another form of the metallic coating.
  - The most common form of this would be hot dip galvanizing.
  - **Hot-dip galvanizing is most commonly applied to steels to offer cathodic protection.**
  - The thickness of the coating obtained via hot-dip galvanizing is much thicker than would be achieved by zinc plating, and, thus offers superior corrosion protection.
  - A thicker layer of zinc offers larger amounts of the anodically charged zinc relative to steel.
  - Because this form of protection is fairly cheap and easy to apply, it's very commonly used as a protective coating on substrates.
- 

129. Answer: d

---

## Explanation:

### Concept:

#### Acceleration Due to Gravity :

- The force of attraction exerted by the earth on a body is called gravitational pull or gravity .
  - We know that when a force acts on a body , it produces acceleration . Therefore, a body under the effect of gravitational pull must accelerate .
  - The acceleration produced in the motion of a body under the effect of gravity is called acceleration due to gravity , it is denoted by  $g$ .
  - **The acceleration due to gravity on the surface of the earth is  $9.81 \text{ m-s}^{-2}$**
- 

130. Answer: d

## Explanation:

### Explanation:

The air-standard-Otto cycle is the idealized cycle for the spark-ignition internal combustion engines.

The Otto cycle 1-2-3-4 consists of the following four processes:

- Process 1-2: Reversible adiabatic compression of air
- Process 2-3: Heat addition at constant volume
- Process 3-4: Reversible adiabatic expansion of air
- Process 4-1: Heat rejection at constant volume

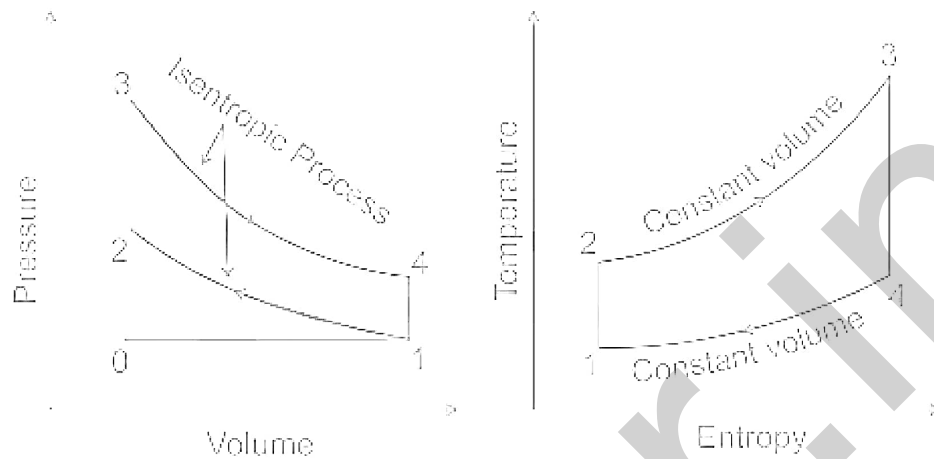

### Important Points

Otto Cycle	<ul style="list-style-type: none"> <li>• Constant volume heat rejection.</li> <li>• Constant volume heat addition.</li> </ul>
Carnot Cycle	<ul style="list-style-type: none"> <li>• Constant temperature heat rejection.</li> <li>• Constant temperature heat rejection.</li> </ul>
Diesel Cycle	<ul style="list-style-type: none"> <li>• Constant pressure heat addition.</li> <li>• Constant volume heat rejection.</li> </ul>
Dual Cycle	<ul style="list-style-type: none"> <li>• Constant volume and constant pressure heat addition</li> <li>• Constant volume heat rejection</li> </ul>

131. Answer: a

Explanation:



### Concept:

The efficiency of an air standard Otto cycle is given by -

$$\eta_{Otto} = 1 - \frac{1}{r^{\gamma-1}}$$

where

$r$  = compression ratio,  $\gamma$  = ratio of specific heat  $C_p/C_v \Rightarrow 1.4$  for ideal gas i.e. Air

The efficiency of the air standard Otto cycle is a function of the compression ratio  $r$  only.

Range  $r_k = 6 - 10$

### Calculation:

#### Given:

$$r_k = 7, \gamma = 1.4$$

$$\therefore \eta_{Otto} = 1 - \frac{1}{r^{\gamma-1}}$$

$$\Rightarrow 1 - \frac{1}{7^{0.4}}$$

$$\Rightarrow 54.08 \% \approx 54 \%$$



## Important Point

### Otto Cycle

- Air standard cycle for **spark ignition (SI)** engine.
- Piston executes four complete strokes within the cylinder, and the crankshaft completes two revolutions for each thermodynamic cycle.

**P-V Diagram & T-S Diagram:**

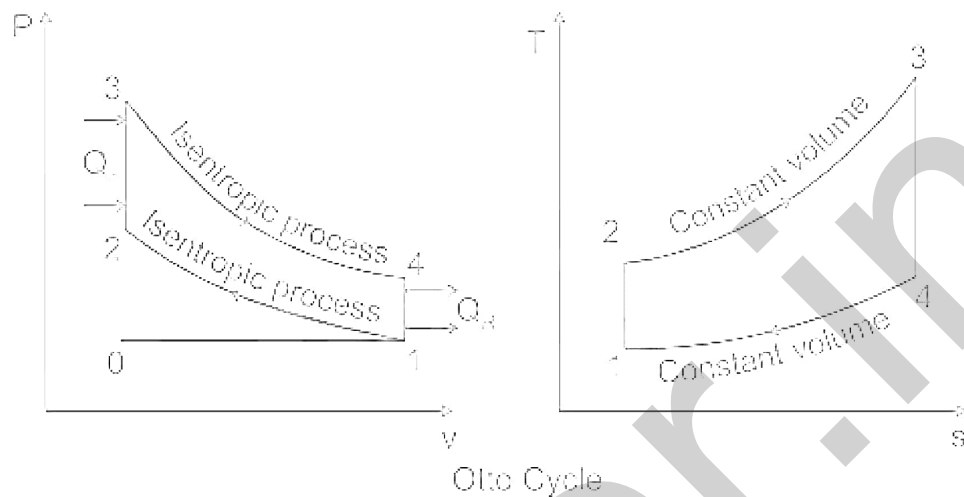

**Process 1-2 (Compression)** - Reversible adiabatic compression

$$\Rightarrow \frac{T_2}{T_1} = \left(\frac{v_1}{v_2}\right)^{\gamma-1}$$

**Process 2-3 (Combustion)** - Constant volume heat addition.

$$Q_1 = Q_{2-3} = mc_v(T_3 - T_2)$$

**Process 3-4 (Expansion)** - Reversible adiabatic expansion.

$$\Rightarrow \frac{T_3}{T_4} = \left(\frac{v_4}{v_3}\right)^{\gamma-1} = \left(\frac{v_1}{v_2}\right)^{\gamma-1}$$

**Process 4-1 (Exhaust)** - Constant volume heat rejection.

$$Q_2 = Q_{4-1} = mc_v(T_4 - T_1)$$

132. Answer: b

**Explanation:**

Explanation:

- As the force is applied to the body the friction force acts on the body which will be opposite to the applied force.

- As the value of  $P$  is going on increasing, at some stage the solid body will be on the verge of motion.
- The friction force corresponding to this stage is called the limiting force of friction.

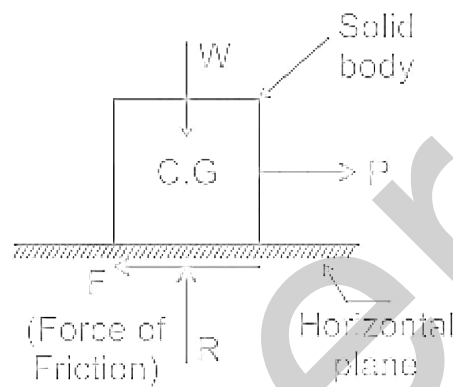

### Important Points

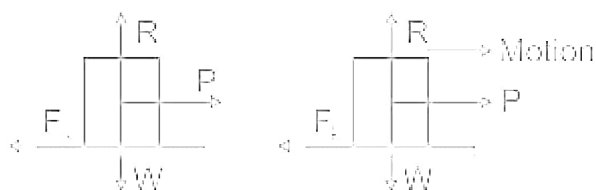
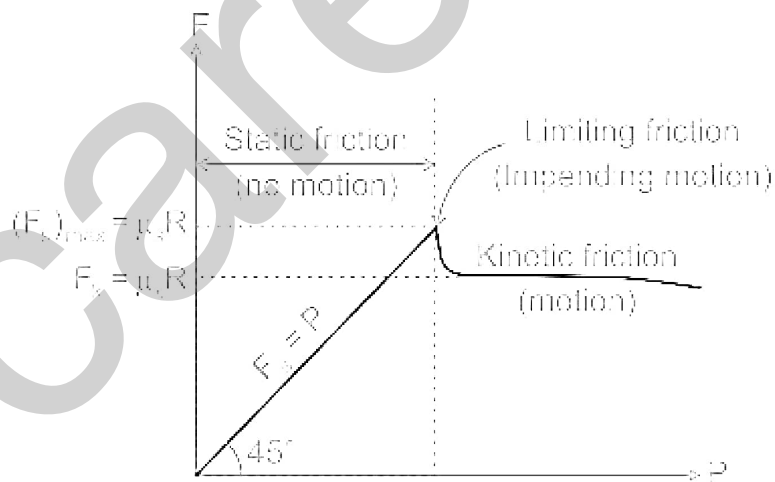

Law of limiting friction for dry surfaces:

- When two bodies are in contact, the direction of the force of friction on one of them is opposite to the direction in which this body has the tendency to move
- The frictional force is independent of the area of contact of the surfaces

- 
- When one body is just on the point of sliding over the other body, the maximum force of friction is being exerted, This is called the limiting friction
  - The force of friction is dependent upon the type of materials of the two bodies in contact
  - The limiting frictional force is proportional to the normal force that acts between the bodies in contact
  - The ratio of frictional force to the normal reaction is constant and is known as the coefficient of friction i.e.  $\mu = F/N$
  - Limiting static friction is somewhat greater than the kinetic friction
  - The kinetic friction is independent of the relative velocity of the bodies in contact
- 

133. Answer: b

**Explanation:**

Explanation:

- **Optical character recognition** (also optical character reader, OCR) is the mechanical or electronic **conversion of images** of typed, handwritten or printed text into machine-encoded text, whether from a scanned document, a photo of a document, a scene-photo (for example the text on signs and billboards in a landscape photo) or from subtitle text superimposed on an image (for example from a television broadcast).
- It is widely used as a form of information entry from printed paper data records, whether passport documents, invoices, bank statements, computerized receipts, business cards, mail, printouts of static-data, or any suitable documentation.
- It is a common method of digitizing printed texts so that they can be electronically edited, searched, stored more compactly, displayed online, and used in machine processes such as cognitive computing, machine translation, (extracted) text-to-speech, key data, and text mining. OCR is a field of research in pattern recognition, artificial intelligence, and computer vision.

---

---

134. Answer: c

**Explanation:**

The correct answer is Character set of 64.

Important Points

- BCD (Binary Coded Decimal) is simply the 4-bit binary code representation of a decimal digit.
  - Each decimal digit replaced in the integer and fractional parts by its binary equivalent.
  - BCD Code uses four bits to represent the 10 decimal digits of 0 to 9.
  - BCD code is often called 8421 because the BCD is a weighted code and the weights used in binary coded decimal code are 8, 4, 2, 1.
- The first 8-bit Extended Binary Coded Decimal Interchange Code (EBCDIC) introduced by IBM.

---

135. Answer: a

**Explanation:**

Explanation:

Streamline:

$$u = \frac{\partial \psi}{\partial y}, v = -\frac{\partial \psi}{\partial x}$$

$$d\psi = \frac{\partial \psi}{\partial x} dx + \frac{\partial \psi}{\partial y} dy = 0$$

$$\frac{dy}{dx} = -\frac{\frac{\partial \psi}{\partial x}}{\frac{\partial \psi}{\partial y}} = \frac{v}{u}$$

Potential line:

$$u = \frac{\partial \phi}{\partial x}, v = \frac{\partial \phi}{\partial y}$$

$$d\phi = \frac{\partial\phi}{\partial x}dx + \frac{\partial\phi}{\partial y}dy = 0$$

$$\frac{dy}{dx} = -\frac{\frac{\partial\phi}{\partial x}}{\frac{\partial\phi}{\partial y}} = -\frac{u}{v}$$

The slope of the velocity potential  $= \left(\frac{dy}{dx}\right)_1 = -\frac{u}{v}$

The slope of the stream-line  $\left(\frac{dy}{dx}\right)_2 = \frac{v}{u}$

$$\left(\frac{dy}{dx}\right)_1 \times \left(\frac{dy}{dx}\right)_2 = -\frac{u}{v} \times \frac{v}{u} = -1$$

Hence, they are orthogonal to each other ( $\because m_1 m_2 = -1$ )

136. Answer: c

**Explanation:**

**Concept:**

Parallel Axis Theorem:

The moment of inertia of a body about an axis parallel to the body passing through its center is equal to the sum of moment of inertia of the body about the axis passing through the center and product of the area of the body times the square of the distance between the two axes

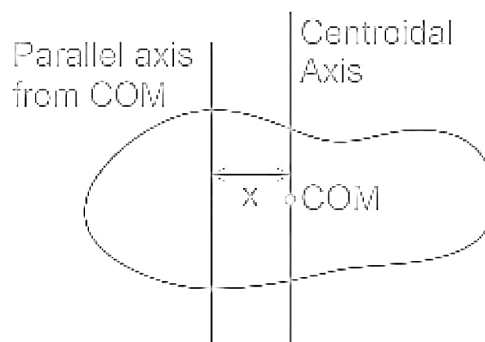

$$I = I_{com} + Ax^2$$

**Calculation:**

---

Given:

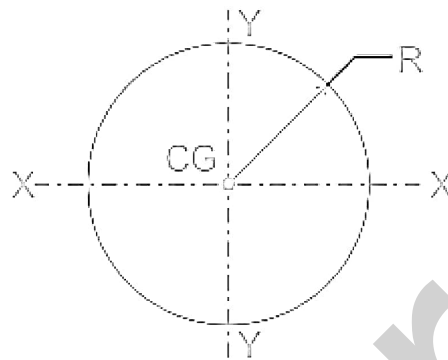

The Moment of Inertia of a circle about the centroidal axis is:

$$I_{xx} = I_{yy} = \frac{\pi d^4}{64} \Rightarrow \frac{\pi r^4}{4}$$

### Important Points

The following table shows the Second moment of inertia of different shapes

Shape	Figure	Moment of Inertia
Rectangle		$I_{xx} = \frac{bd^3}{12}$ $I_{yy} = \frac{db^3}{12}$
Triangle		$I_{xx} = \frac{bh^3}{36}$ $I_{yy} = \frac{hb^3}{36}$
Circle		$I_{xx} = \frac{\pi d^4}{64}$ $I_{yy} = \frac{\pi d^4}{64}$
Semicircle		$I_{xx} = 0.11R^4$ $I_{yy} = \frac{\pi R^4}{8}$
Quarter circle		$I_{xx} = 0.055R^4$



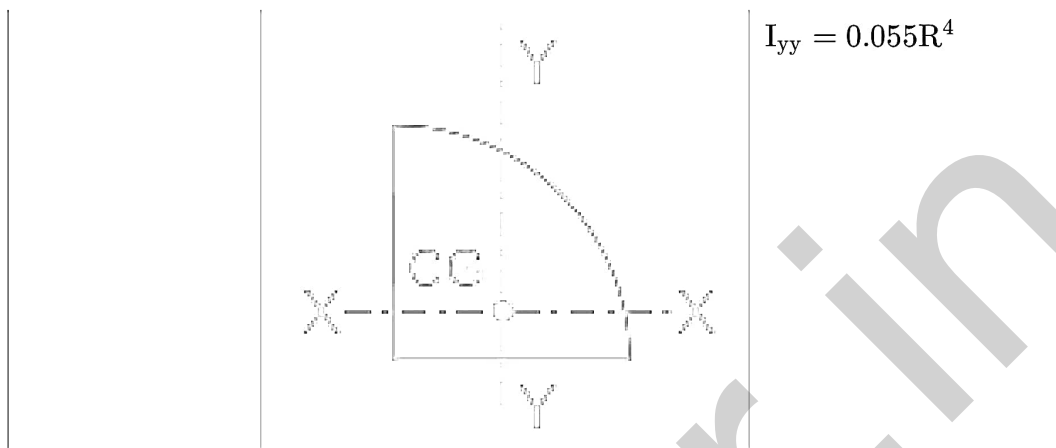

137. Answer: c

**Explanation:**

Explanation:

**Radius and fillet Gauge:**

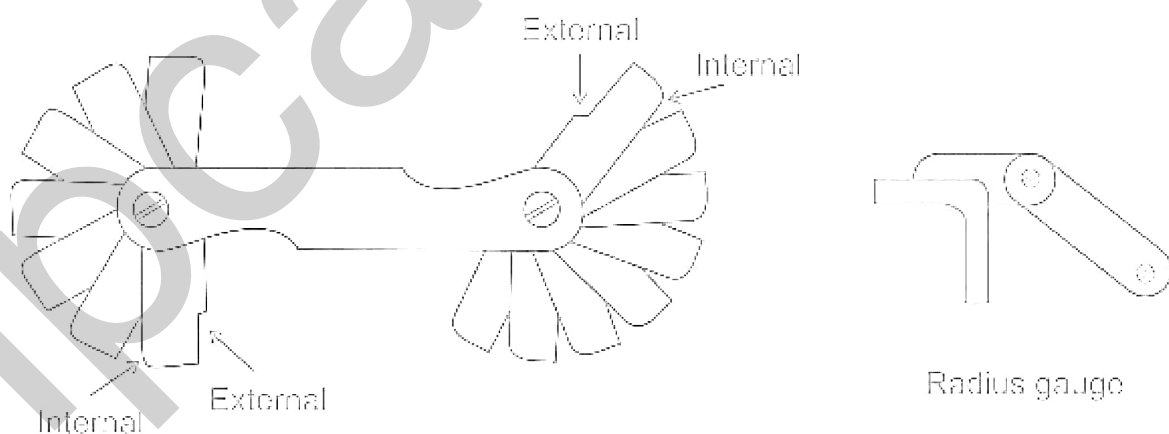

- Components are machined to have curved formation on the edges or at the junction, Accordingly, they are called radius and fillets
- They are made of hardened sheet metal each to a precise radius
- They are used to check the radii by comparing the radius on a part with the radius of the gauges
- Application of radius gauge to check the radius formed externally

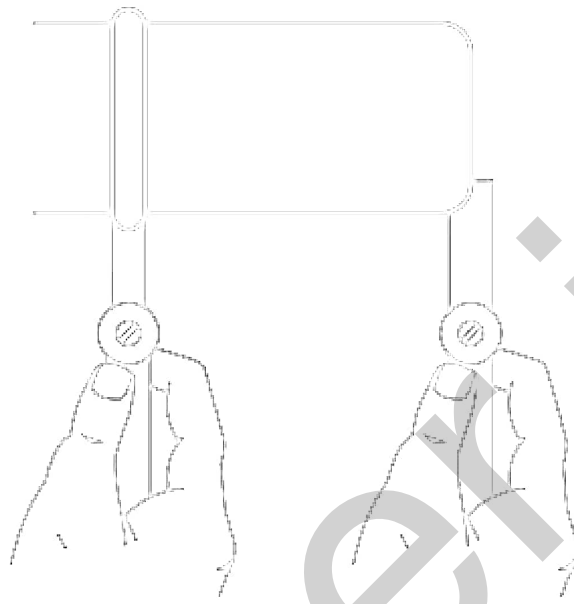

- Application of a fillet gauge to check the fillet formed on a turned component

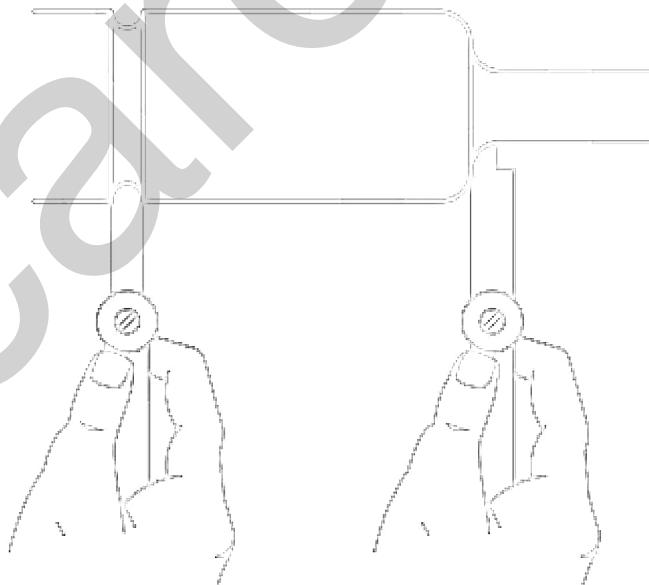

---

138. Answer: d

Explanation:

Explanation:

Single point cutting tool

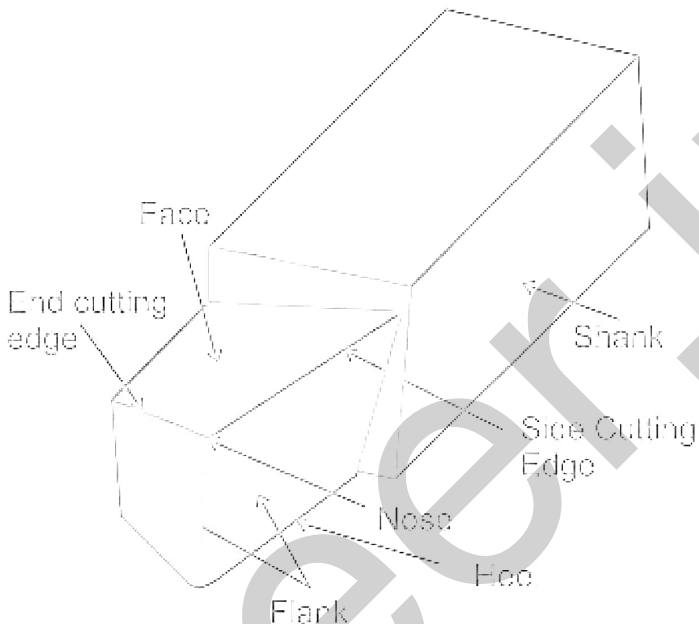

mpcareer.in

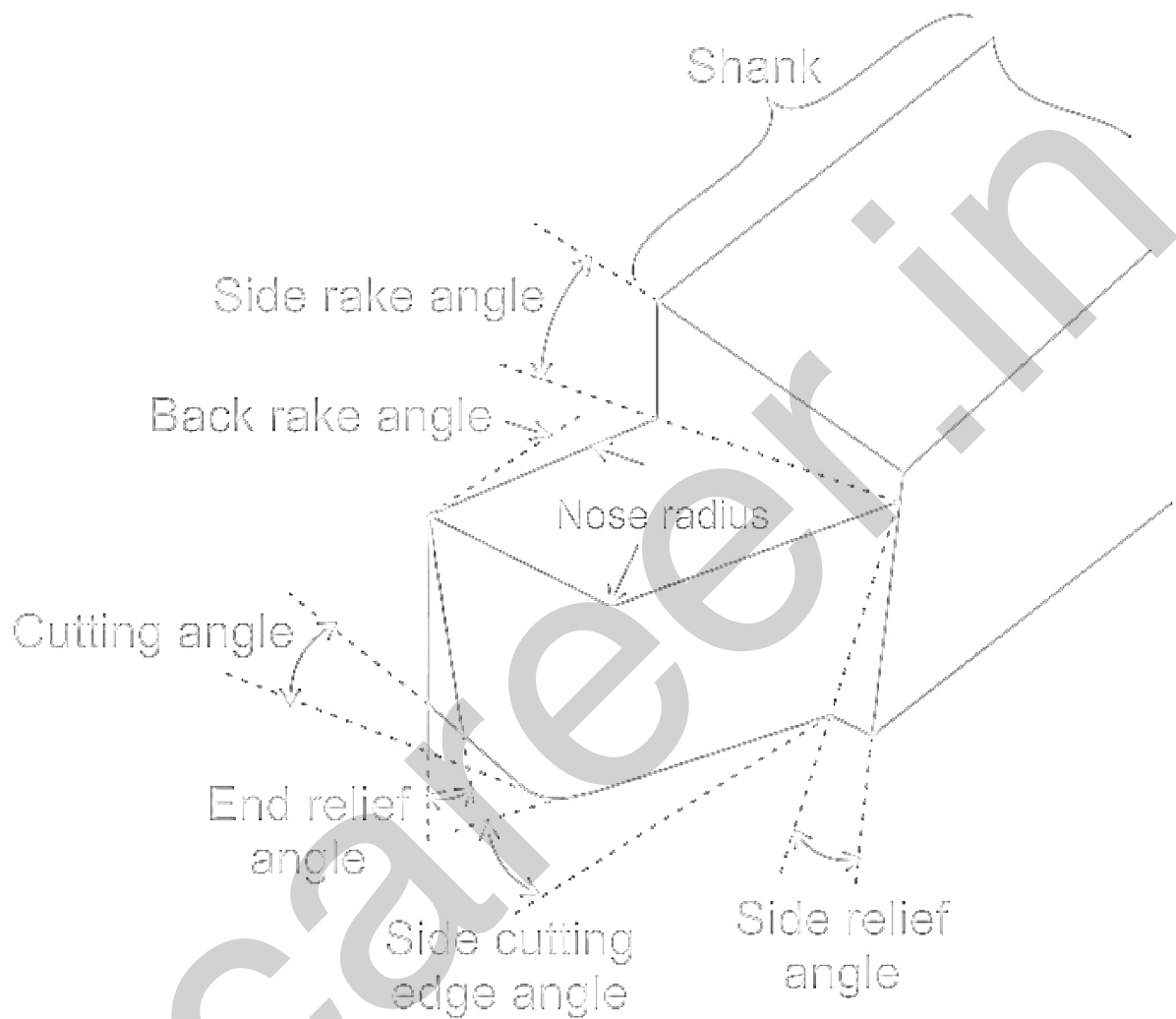

<b>Nose</b>	It is the intersection of side cutting edge and end cutting edge
<b>Heel</b>	It is the intersection of the <b>flank</b> and <b>base</b> of the tool
<b>Shank</b>	It is the main body of a tool
<b>Base</b>	It is the bottom part of the shank. It takes the tangential force of cutting

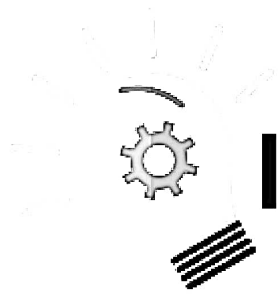

---

# Important Point

## Face:

- Face is the surface of the tool on which chip impinges when separated from work-piece

## Side Cutting Edge Angle:

- The angle between side cutting edge and side of the tool shank is called side cutting edge angle.
- It is also called lead angle or principle cutting angle.

## End Cutting Edge Angle:

- The angle between the end cutting edge and a line perpendicular to the shank of the tool is called end cutting edge angle.

## Side Relief Angle:

- The angle between the portion of the side flank immediately below the side cutting edge and the line perpendicular to the base of the tool measured at right angles to the side flank is known as side relief angle.
- It is the angle that prevents interference, as the tool enters the work material.

## End Relief Angle:

- End relief angle is the angle between the portion of the end flank immediately below the end cutting edge and the line perpendicular to the base of the tool, measured at right angles to end flank.
- It is the angle that allows the tool to cut without rubbing on the work-piece.

## Back Rake Angle:

- 
- The angle between the face of the tool and a line parallel with the base of the tool, measured in a perpendicular plane through the side cutting edge is called back rake angle.
  - It is the angle that measures the slope of the face of the tool from the nose toward the rear.
  - If the slope is downward toward the nose, it is a negative back rake angle. And if the slope is downward from the nose, it is a positive back rake angle. If there is not any slope, the back rake angle is zero.

**Side Rake Angle:**

- The angle between the face of the tool and a line parallel with the base of the tool, measured in a plane perpendicular to the base and side cutting edge is called the side rake angle.
  - It is the angle that measures the slope of the tool face from cutting edge. If the slope is towards the cutting edge, it is a negative side rake angle.
  - If the slope is away from the cutting edge, it is a positive side rake angle.
- 

139. Answer: b

**Explanation:**

Explanation:

TYPE	PROCESS
Electrolysis	<ul style="list-style-type: none"> <li>◦ Electrolysis is defined as a process of decomposing ionic compounds into their elements by passing a direct electric current through the compound in a fluid form.</li> <li>◦ The cations are reduced at the cathode and anions are oxidized at the anode.</li> <li>◦ <math>2\text{H}_2\text{O} \rightarrow 2\text{H}_2 + \text{O}_2</math></li> </ul>
Displacement Reaction	<ul style="list-style-type: none"> <li>◦ A displacement reaction is the one wherein the atom or set of atoms is displaced by another atom in a molecule. It is two types-</li> <li>◦ <b>I) Single decomposition</b></li> <li>◦ <math>\text{A} + \text{B}-\text{C} \rightarrow \text{A}-\text{B} + \text{C}</math></li> <li>◦ <math>\text{Cl}_2 + 2\text{NaBr} \rightarrow 2\text{NaCl} + \text{Br}_2</math></li> <li>◦ <b>II) Double decomposition</b></li> <li>◦ <math>\text{A}-\text{B} + \text{C}-\text{D} \rightarrow \text{A}-\text{D} + \text{C}-\text{B}</math></li> <li>◦ <math>\text{BaCl}_2 + \text{Na}_2\text{SO}_4 \rightarrow \text{BaSO}_4 + 2\text{NaCl}</math></li> </ul>
Thermal Decomposition	<ul style="list-style-type: none"> <li>◦ A decomposition reaction is activated by thermal energy. Generally, it is endothermic as energy is required to break the chemical bond to separate constituent elements.</li> <li>◦ <math>\text{A} \rightarrow \text{B} + \text{C}</math></li> <li>◦ <math>\text{CaCO}_3 \rightarrow \text{CaO} + \text{CO}_2</math></li> </ul>
Photochemical Decomposition	<ul style="list-style-type: none"> <li>◦ It is a type of decomposition reaction in which the reactant is broken down to its constituents by photons.</li> <li>◦ Photolysis occurs in the atmosphere where the Ozone molecule is broken down into an oxygen molecule and oxygen atom.</li> </ul>

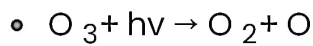

140. Answer: a

### Explanation:

#### Concept:

#### Malleability

- Malleability is the property by virtue of which a material may be **hammered or rolled into thin sheets** without rupture. This property generally increases with the increase of temperature.
- Malleability is the ability of a metal to exhibit large deformation or plastic response when being subjected to compressive force.
- Lead, soft steel, wrought iron, copper and aluminum are some materials in order of diminishing malleability.

#### Important Points

#### Ductility

- Ductility is the property of the material that enables it to be drawn out or elongated to an appreciable extent before rupture occurs.
- The percentage elongation or percentage reduction in area before rupture of a test specimen is the measure of ductility. Normally if percentage elongation exceeds 15% the material is ductile and if it is less than 5% the material is brittle.
- Lead, copper, aluminum, mild steel are typical ductile materials.

#### Brittleness

- Brittleness is opposite to ductility. Brittle materials show little deformation before fracture and failure occurs suddenly without any warning i.e. it is the property of breaking without much permanent distortion.



- 
- Normally if the elongation is less than 5% the material is brittle. E.g. cast iron, glass, ceramics are typical brittle materials.
- 

141. Answer: b

### Explanation:

#### Explanation:

#### Shear Thinning:

- A fluid is called shear thinning if the viscosity decreases as the shear rate increases.
- Shear-thinning fluids, also known as pseudo-plastics, generally find their applications in industrial and biological processes.
- Common examples include ketchup, paints, and blood.

#### Shear Thickening:

- A fluid is called shear thickening if the viscosity of the fluid increases as the shear rate increases.
- **Shear thickening fluids, also known as Dilatant**
- A common example of shear thickening fluids is a mixture of cornstarch and water.

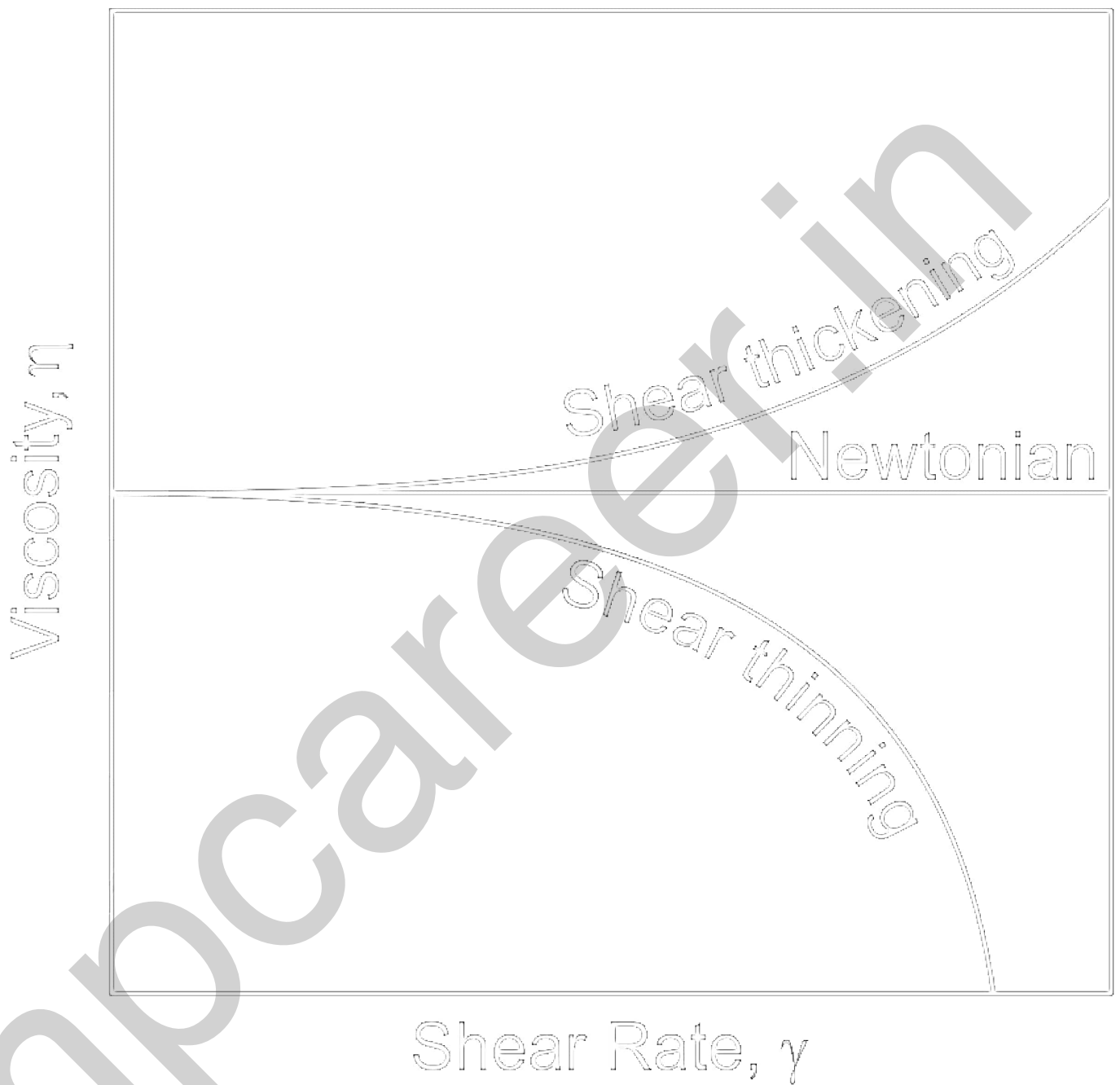

142. Answer: a

Explanation:

Explanation:

Bleeding:

- Bleeding is the process of **draining steam** from the turbine, at certain points during its expansion, and using this steam for **heating the feed-water** supplied to the boiler.
- The Ideal Rankine cycle, modified to take into account the **effect of bleeding** is known as the **Regenerative cycle**.

### Rankine Cycle:

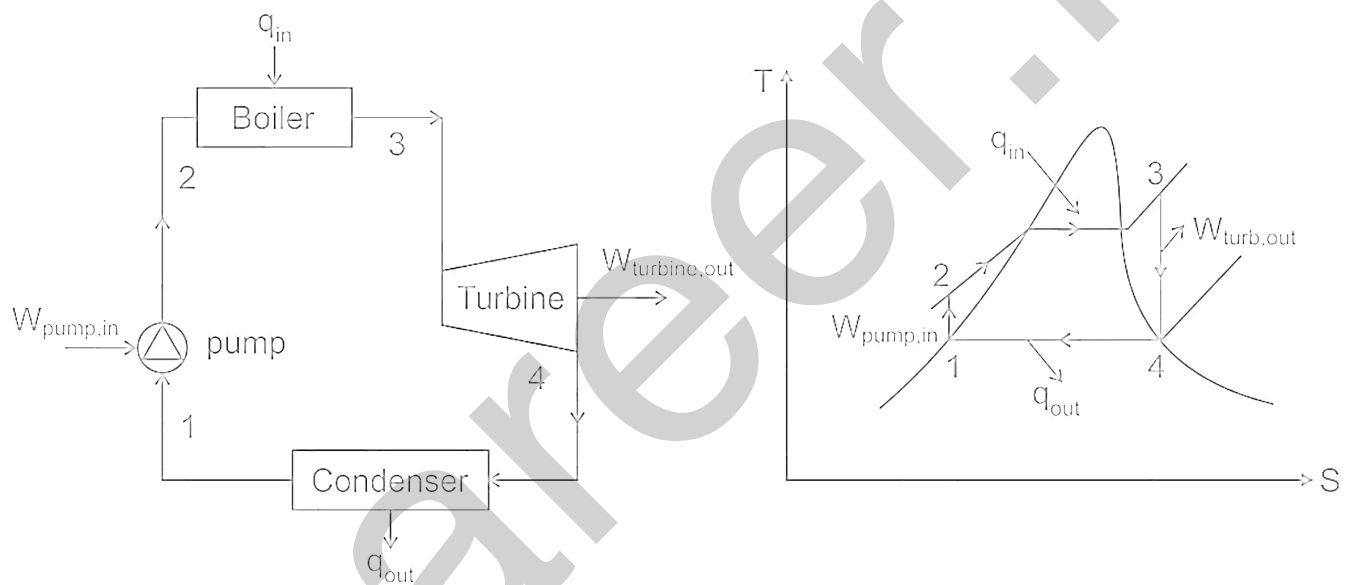

**Process 3-4:** Isentropic expansion in Turbine ( $W_T$ )

**Process 4-1:** Constant pressure heat removal in Condenser ( $Q_2$ )

**Process 1-2:** Isentropic compression in Pump ( $W_P$ )

**Process 2-3:** Constant pressure heat addition in Boiler ( $Q_1$ )

### Important Points

#### Governing

- Steam turbine governing is the procedure of controlling the flow rate of steam to a steam turbine so as to maintain its speed of rotation is constant.
- The variation in load during the operation of a steam turbine can have a significant impact on its performance.

---

## Reheating

- In the reheat cycle, the total expansion of steam from the boiler to condenser pressure is carried out in more than one stage with reheating of steam in between the stages.
- The main advantage of the reheat cycle is that it increases the dryness fractions of steam at condenser inlet thus making it possible to use higher boiler pressure. It also increases the net-work output thus decreasing the mass flow rate of steam required for the same power output.
- By reheating it's not sure that efficiency will increase, it may decrease also depending on the mean temperature of heat addition.
- Also, the mean temperature of heat addition doesn't always increase. It depends on the pressure in the reheater and entry pressure.

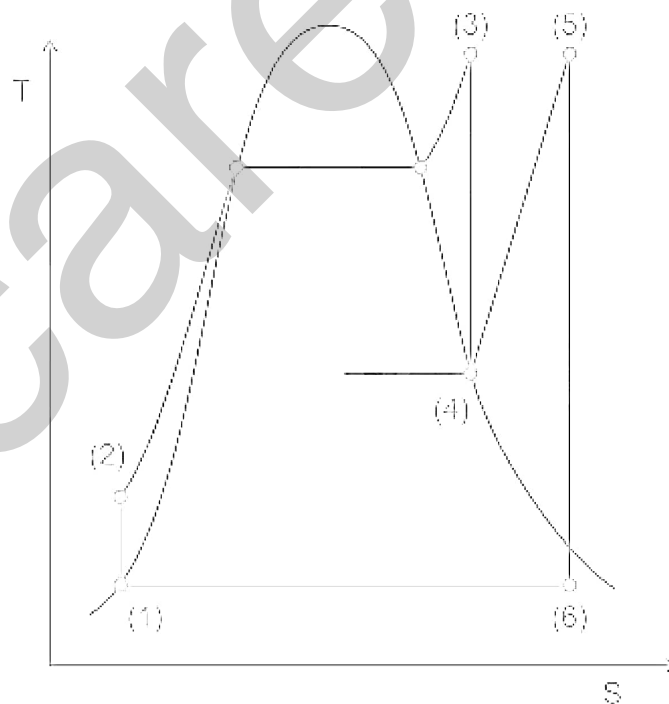

---

143. Answer: c

**Explanation:**

Explanation:

- 
- The memory unit is the amount of data that can be stored in the storage unit. This storage capacity is expressed in terms of Bytes .
  - Bit (Binary Digit) : A binary digit is logical 0 and 1 representing a passive or an active state of a component in an electric circuit.
  - Nibble : A group of 4 bits is called a nibble.
  - Byte : A group of 8 bits is called byte. A byte is the smallest unit, which can represent a data item or a character.
  - Word: A computer word, like a byte, is a group of a fixed number of bits processed as a unit, which varies from computer to computer but is fixed for each computer.

Memory units with no. of Bytes:

Memory units	Bytes
Kilobyte(KB)	1024Bytes
Megabyte(MB)	1024KB
Gigabyte(GB)	1024MB
Terabyte(TB)	1024GB

---

144. Answer: c

**Explanation:**

The correct answer is All of the options.

**Important Points**

- This Consolidated fund is filled by the Direct and indirect taxes Loans taken by the Indian government and returning of loans/interests of loans to the government by anyone/agency that has taken it.
  - The government needs parliamentary approval to withdraw money from the Consolidated Fund.

- 
- The provision for a Consolidated fund is given in **Article 266(1)** of the Constitution of India.
  - The provision for the **Contingency fund** is given in **Article 267 (1)** of the Constitution of India.
    - **Its fixed corpus is Rs. 500 crores.**
  - **Public Accounts of India** is constituted under **Article 266(2)** of the Constitution.
    - **The government does not need permission to take advances from a public account.**
- 

145. Answer: c

**Explanation:**

The correct answer is Kochi.

Important Points

- Kochi in Kerala, the land of God's own country set up India's first oceanarium in 2010.
  - This project has been taken in a bid to promote 'fisheries tourism' and to enable people and researchers to study marine species, including large ones like whales and sharks.
  - An oceanarium is a simulated ocean and contains all living organisms found in the water body including large species like whales and sharks.
- 

146. Answer: c

**Explanation:**

Explanation:

Slip gauge

- Slip gauges or gauge blocks are used as standards for precision length measurement.
- These gauges are made in sets and consist of a number of hardened blocks made of high-grade steel with low thermal expansion.
- **It is also famous with the name of Johanssen Gauges**
- These slip gauges are available in various sets with different numbers.
- A particular size can be built up by wringing individual slip gauges together.
- Wringing is the act of joining the slip gauges together while building up to sizes.
- The faces of the slip gauges are finished by Lapping only.

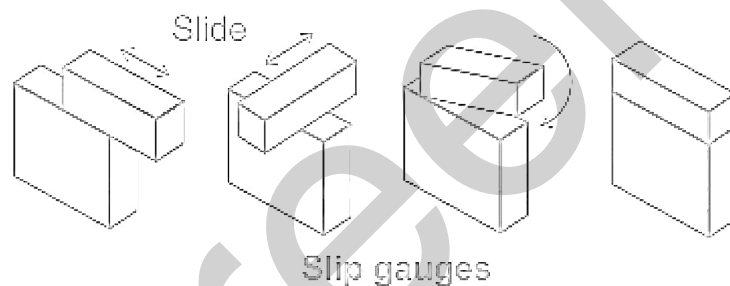

### Important Points

Feeler gauge: Feeler gauge is used to check the gap between the mating parts.

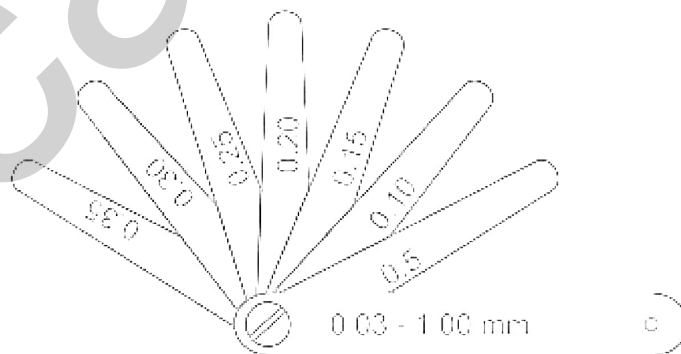

Radius and fillet gauge: Components are machined to have curved formation on the edges or at the junction of two parts, which are known as fillet. The gauges used to check the radius of fillet are fillet gauges.

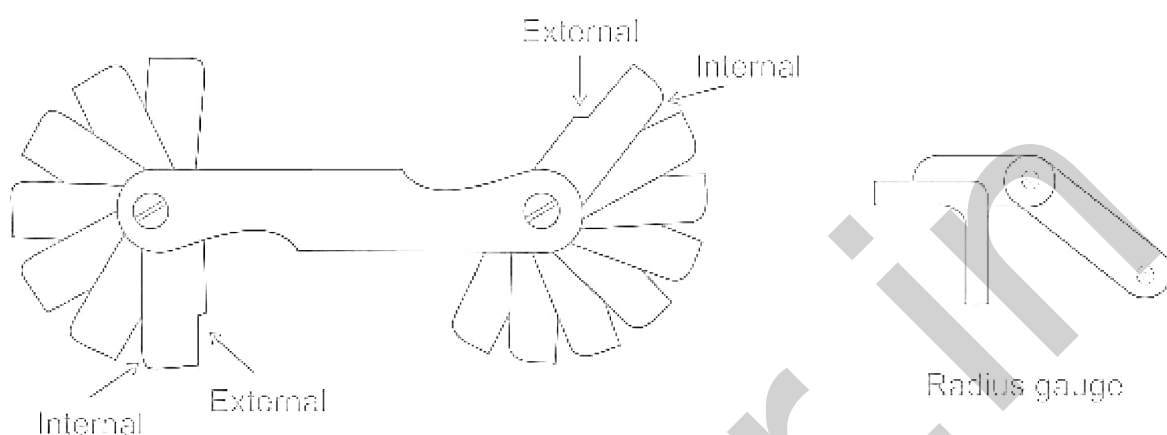

Scr

147. Answer: b

**Explanation:**

The correct answer is Amplitude.

**Key Points**

- The **amplitude** of a wave refers to **the maximum amount of displacement of a particle on the medium from its rest position**.
  - **Amplitude determines the loudness**, the more amplitude of a wave, the more the loudness produces.
- **Oscillation is a periodic motion that repeats itself in a regular cycle**. Such as Sine wave, the side-to-side swing of a pendulum, or the up-and-down motion of spring with a weight.
  - In an oscillating system, **the force always acts in a direction opposite to the displacement of the particle from the equilibrium point**.
  - In a pendulum clock, there is a change from potential energy to kinetic energy with each swing.
- Frequency is the number of compressions or rarefactions taken together passing through a point in one second.
  - **The pitch is determined by the frequency of the wave**. Higher the frequency of a wave more its pitch.



- The wavelength is the distance between adjacent identical parts of a wave.

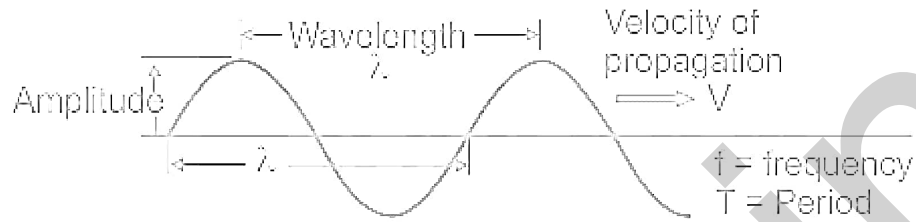

### Important Points

- The relationship of the speed of sound, its frequency, and wavelength is the same as for all waves:  $v = f\lambda$ , where  $v$  is the speed of sound,  $f$  is its frequency, and  $\lambda$  is its wavelength.

148. Answer: a

### **Explanation:**

Explanation:

Mach number

Mach number is defined as the ratio of inertia force to elastic force.

$$M = \sqrt{\frac{\text{Inertia force}}{\text{Elastic force}}} = \sqrt{\frac{\rho AV^2}{KA}} = \sqrt{\frac{V^2}{\frac{K}{\rho}}} = \frac{V}{\sqrt{\frac{K}{\rho}}} = \frac{V}{C} \quad \left\{ \sqrt{\frac{K}{\rho}} = C = \text{Velocity of sound} \right\}$$

$$M = \frac{\text{Velocity of body moving in fluid}}{\text{velocity of sound in fluid}}$$

For the compressible fluid flow, Mach number is an important dimensionless parameter. On the basis of the Mach number, the flow is defined.

Mach Number	Type of flow
$M < 0.8$	Sub-sonic flow
$0.8 < M < 1.3$	Trans-sonic
$M = 1$	Sonic flow
$1.3 < M < 5$	Super-sonic flow
$M > 5$	Hypersonic flow

### Important Points

Other important dimensionless numbers are described in the table below

Reynold's number	$R_e = \frac{\text{inertia force}}{\text{viscous force}} = \frac{\rho V L}{\mu}$
Froude Number	$F_r = \sqrt{\frac{\text{inertia force}}{\text{gravitation force}}} = \frac{V}{\sqrt{Lg}}$
Euler number	$E_u = \sqrt{\frac{\text{inertia force}}{\text{pressure force}}} = \frac{V}{\sqrt{P/\rho}}$
Weber Number	$W_e = \sqrt{\frac{\text{inertia force}}{\text{surface tension}}} = \frac{V}{\sqrt{\sigma/\rho L}}$

---

149. Answer: a

**Explanation:**

Explanation:

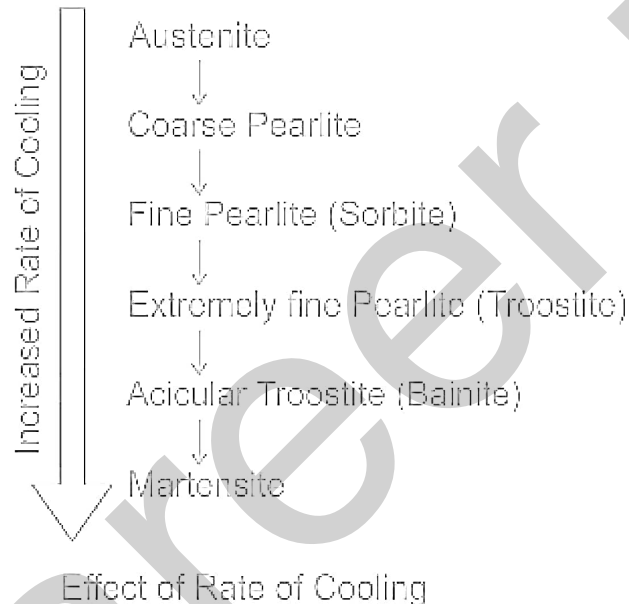

Martensite:

- It is a metastable phase of steel formed by the transformation of austenite below 320°C.
- Martensite is an interstitial supersaturated solid solution of carbon in  $\alpha$ -Iron and has a body-centered tetragonal lattice.
- It has a carbon content of up to 2% and is extremely hard and brittle.
- It is a product of rapid cooling (quenching) and possesses an acicular or needle-like structure.
- The rate of cooling and the amount of carbon percentage in steel are directly proportional to the amount of hardness achieved in martensitic transformation.

Bainite:

- It is a plate-like microstructure that forms in steels at a temperature of 125-550° (depending on alloy content).

- 
- It forms by the decomposition of austenite at a temperature which is above  $M_S$  but below that at which fine pearlite forms.

Austenite:

- It is also known as Gamma-phase iron is a metallic, non-magnetic allotrope of iron or solid solution of iron, with an alloying element.
- In plain carbon steel, austenite exists above the critical eutectoid temperature of 1000 K.
- Austenite is of FCC crystal structure.

Pearlite:

- It is a two-phase, lamellar structure composed of 88% ferrite and 12% cementite.
  - Pearlite is formed when austenite cools slowly below  $727^\circ\text{C}$ . It is hard as well as strong because of the layered structure.
  - It finds wide application in cutting tools, knives, high strength wire, etc.
- 

150. Answer: a

**Explanation:**

Explanation:

Resistance spot welding occurs in four steps. They are as follows:

**Squeeze time:**

- The time required for the electrodes to align and clamp the work-piece together and provide necessary electrical contact.

**Weld time:**

- Time the current flows through the work-piece till they are heated to melting temperature.

### Hold time:

- Time till the pressure is maintained, without the current, wherein the pieces are expected to get forge weld.

### Off time:

- When the pressure of the electrode is taken off so that plates can be positioned for the next spot.

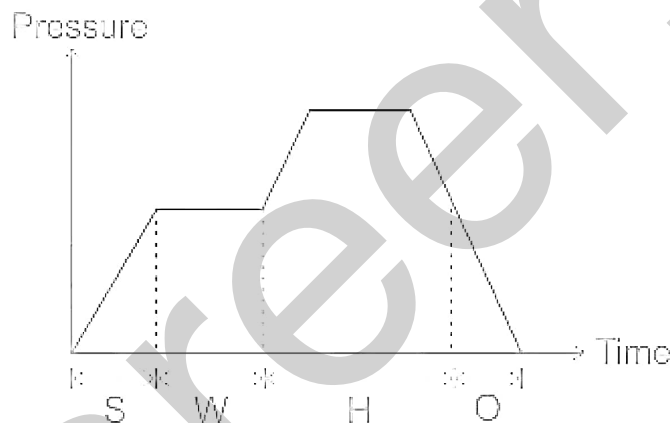

## Important Point

### Resistance welding:

- This process makes use of the **electrical resistance** for generating heat that is required for melting the work-piece.
- Generally used to and **join thin plate structures**.
- Also considered as a **green process** since it does not generate gases and flames as in metal arc welding and gas welding.
- The heat generated in Resistance welding is given by  $H = I^2Rt$

H = Heat generated, I = Current, R = Resistance of joint, t = Time of flow of current.

- Resistance depends upon:

- work-piece to be joined
- electrode used
- gap resistance

## Types:

### Spot welding

- Individual weld is produced by momentary application of pressure and resistance into the work-piece.

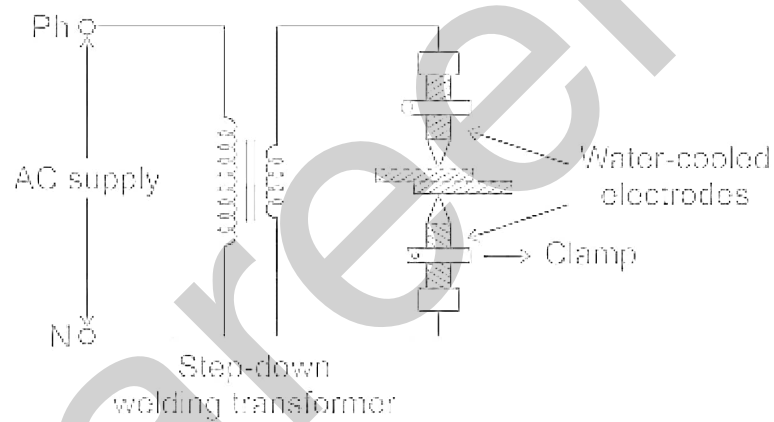

### Seam welding

- It can produce continuous fast and leak-proof weld mainly used for thin metallic sheets, galvanized roofing, small tanks, etc

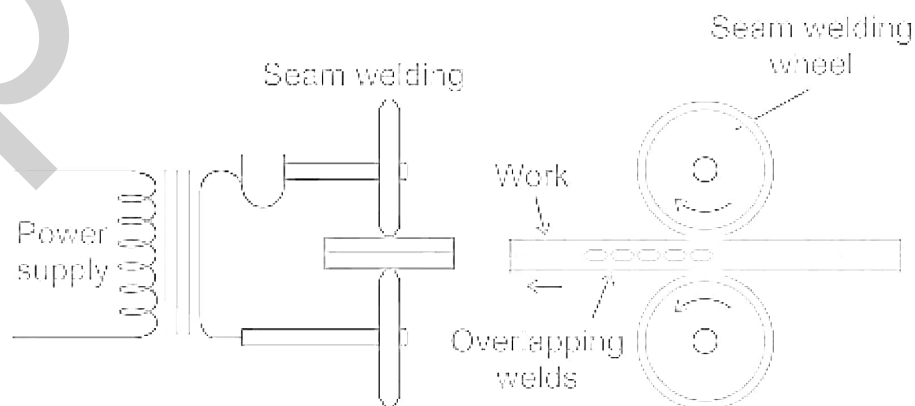

### Projection welding

- A dimple is embossed into one of the work-piece at the locations where the weld is desired.

